

WavePort User's Manual

High-Speed Portable Data Acquisition Systems



the smart approach to instrumentation™

IOtech, Inc.

25971 Cannon Road
Cleveland, OH 44146-1833
Phone: (440) 439-4091
Fax: (440) 439-4093

E-mail (Product Information): sales@iotech.com
E-mail (Technical Support): productsupport@iotech.com
Internet: www.iotech.com

WavePort User's Manual *High-Speed Portable Data Acquisition Systems*

p/n 1036-0901 Rev. 3.0

Warranty Information

Your IOtech warranty is as stated on the *product warranty card*. You may contact IOtech by phone, fax machine, or e-mail in regard to warranty-related issues.

Phone: (440) 439-4091, fax: (440) 439-4093, e-mail: sales@iotech.com

Limitation of Liability

IOtech, Inc. cannot be held liable for any damages resulting from the use or misuse of this product.

Copyright, Trademark, and Licensing Notice

All IOtech documentation, software, and hardware are copyright with all rights reserved. No part of this product may be copied, reproduced or transmitted by any mechanical, photographic, electronic, or other method without IOtech's prior written consent. IOtech product names are trademarked; other product names, as applicable, are trademarks of their respective holders. All supplied IOtech software (including miscellaneous support files, drivers, and sample programs) may only be used on one installation. You may make archival backup copies.

FCC Statement



IOtech devices emit radio frequency energy in levels compliant with Federal Communications Commission rules (Part 15) for Class A devices. If necessary, refer to the FCC booklet *How To Identify and Resolve Radio-TV Interference Problems* (stock # 004-000-00345-4) which is available from the U.S. Government Printing Office, Washington, D.C. 20402.

CE Notice



Many IOtech products carry the CE marker indicating they comply with the safety and emissions standards of the European Community. As applicable, we ship these products with a Declaration of Conformity stating which specifications and operating conditions apply.

Warnings, Cautions, Notes, and Tips



Refer all service to qualified personnel. This caution symbol warns of possible personal injury or equipment damage under noted conditions. Follow all safety standards of professional practice and the recommendations in this manual. Using this equipment in ways other than described in this manual can present serious safety hazards or cause equipment damage.



This warning symbol is used in this manual or on the equipment to warn of possible injury or death from electrical shock under noted conditions.



This ESD caution symbol urges proper handling of equipment or components sensitive to damage from electrostatic discharge. Proper handling guidelines include the use of grounded anti-static mats and wrist straps, ESD-protective bags and cartons, and related procedures.



This symbol indicates the message is important, but is not of a Warning or Caution category. These notes can be of great benefit to the user, and should be read.



In this manual, the book symbol always precedes the words "Reference Note." This type of note identifies the location of additional information that may prove helpful. References may be made to other chapters or other documentation.



Tips provide advice that may save time during a procedure, or help to clarify an issue. Tips may include additional reference.

Specifications and Calibration

Specifications are subject to change without notice. Significant changes will be addressed in an addendum or revision to the manual. As applicable, IOtech calibrates its hardware to published specifications. Periodic hardware calibration is not covered under the warranty and must be performed by qualified personnel as specified in this manual. Improper calibration procedures may void the warranty.

Quality Notice



IOtech has maintained ISO 9001 certification since 1996. Prior to shipment, we thoroughly test our products and review our documentation to assure the highest quality in all aspects. In a spirit of continuous improvement, IOtech welcomes your suggestions.

Manual Layout

This manual pertains to setup and operation of a WavePort data acquisition system. The material is organized as follows:

Chapter 1: Unpacking and Inspecting your WavePort Package

Chapter 2: An Introduction to WavePort

Chapter 3: System Setup

Chapter 4: Hardware and Operation Reference

Chapter 5: Software, An Introduction

Chapter 6: WaveView

Chapter 7: DIAdem - the PC Workshop, Quick Start and User's Guide

Chapter 8: Troubleshooting

Chapter 9: Maintenance, Service, and Part Replacement

Chapter 10: Specifications

Appendix A: Using Accelerometers

Appendix B: WBK20A PCMCIA Option, Setup Notes

Glossary

WARNING



The Notebook Power receptacle is "LIVE" whenever WavePort is plugged into a live AC power source. The Module Power Switch can not be used to turn this receptacle "Off."

WavePort contains no user serviceable components. Do not remove WavePort's cover plate. Lethal voltages are present which could cause serious injury or death.

CAUTION



Using this equipment in ways other than described in this manual can cause personal injury or equipment damage. Pay special attention to all cautions and warnings.



Reference Note:

Additional information (not available at the time of publication), can be found in ReadMe files, or in supplemental documentation.

Table of Contents

1 – Unpacking and Inspecting your WavePort Package	1-1
2 – An Introduction to WavePort	
<i>What is WavePort?.....</i>	<i>2-1</i>
<i>What Types of I/O Signals Apply to WavePort?.....</i>	<i>2-2</i>
3 – System Setup	
<i>Choosing a Notebook PC</i>	<i>3-1</i>
<i>Attaching the Notebook to WavePort</i>	<i>3-1</i>
<i>Connecting the Communication Cable and Notebook Power Cable</i>	<i>3-4</i>
<i>Connecting the WavePort to Power.....</i>	<i>3-5</i>
<i>Installing Software</i>	<i>3-5</i>
<i>Using the Daq Configuration Applet to Check Connections.....</i>	<i>3-6</i>
<i>A Guide to Using the Daq Configuration Applet</i>	<i>3-7</i>
4 – Hardware and Operation Reference	
<i>WavePort/PE Devices</i>	<i>4-1</i>
Overview	4-2
Basic Operation	4-3
Signal Aspects	4-5
WavePort/PE16	4-5
WavePort/PE8	4-6
<i>WavePort/V Devices</i>	<i>4-8</i>
Overview.....	4-8
Basic Operation	4-9
Signal Aspects	4-10
<i>Ground Connections</i>	<i>4-11</i>
<i>DB25F “Digital I/O, External Clock, TTL Trigger” Connection</i>	<i>4-12</i>
<i>Programmable Features</i>	<i>4-12</i>
<i>Triggers</i>	<i>4-13</i>
Pulse Trigger	4-13
Digital-Pattern Trigger	4-14
Multi-channel Triggering	4-14
External Clock and Counter-Timer	4-15
<i>Power Aspects</i>	<i>4-16</i>
Power Module Operation	4-18
Charging	4-19
Fuse Replacement	4-19
<i>Factory-Installed Option Cards (for WaveBook and WBK10A-based modules)</i>	<i>4-20</i>
WBK11A – Simultaneous Sample and Hold Card.....	4-20
WBK12A and WBK13A Programmable Low-Pass Filter Cards	4-21
<i>WavePort’s Fan</i>	<i>4-22</i>
5 – Software, An Introduction	5-1
6 – WaveView.....	6-1
<i>Software Setup Notice for WavePort... </i>	<i>6-1</i>
<i>Introduction.....</i>	<i>6-2</i>
<i>Software Startup & Sample Acquisition.....</i>	<i>6-2</i>
Startup WaveView.....	6-2
Configure Channels.....	6-4
Configure Acquisition.....	6-5
Collect Data.....	6-6
Store Data [and View File Data], Option.....	6-7
<i>WaveView Configuration Main Window.....</i>	<i>6-7</i>
<i>Data Conversion.....</i>	<i>6-12</i>

Acquisition Configuration.....	6-13
General Information	6-13
Trigger Types	6-14
External Clock and Counter-Timer	6-15
Digital Pattern Trigger.....	6-16
Pulse Trigger	6-17
WaveView Scope Window.....	6-18
WaveView Direct-To-Disk Window...	6-21

7 – DIAdem

Preface	7-2
----------------------	------------

DIAdem Quick Start..... 7-3

Installing DIAdem	7-3
Launching DIAdem from an Acquisition Program	7-3
Using DIAdem with ChartView	7-5
Where to go from here	7-9
DIAdem-VIEW Help Files	7-9
“Examples” Help Files	7-10

DIAdem - the PC Workshop

The Overall Design	7-13
DIAdem Help	7-18
Options	7-19

DIAdem DATA: Loading and Saving Data

The Data Area	7-23
Copying, Pasting, and Deleting Data Channels	7-25
Saving and Opening Data Sets	7-26

DIAdem VIEW: Viewing, Measuring & Editing Data

Viewing Data as Graphs	7-28
Using the Cursor Position to Measure a Graph	7-29
How to Copy or Delete a Graph	7-32
Using Zoom, Scrolling, & Screen Partition	7-33

8 – Troubleshooting

Electrostatic Discharge (ESD), Handling Notice.....	8-1
--	------------

ReadMe Files and the Install CD-ROM	8-1
--	------------

Driver Support.....	8-2
----------------------------	------------

Connection Problems.....	8-2
---------------------------------	------------

32-Bit WaveView Issues.....	8-2
------------------------------------	------------

Windows NT V3.51.....	8-3
------------------------------	------------

Windows 95/98/2000 Problems.....	8-3
---	------------

Resource Settings.....	8-3
-------------------------------	------------

Parallel Port Setup.....	8-3
---------------------------------	------------

Customer Assistance	8-5
----------------------------------	------------

9 – Maintenance, Service, and Part Replacement

General Maintenance.....	9-1
---------------------------------	------------

Fan Filter: Cleaning and Replacement	9-2
---	------------

What Type of Environment is WavePort Intended for?	9-3
---	------------

How Should WavePort be Transported?	9-3
--	------------

Should I Calibrate the WavePort?	9-4
---	------------

How do I get Replacement Parts or Service?	9-4
---	------------

10 - Specifications

Appendix A – Using Accelerometers	A-1
--	------------

Appendix B – WBK20A PCMCIA Option, Setup Notes	B-1
---	------------

Glossary

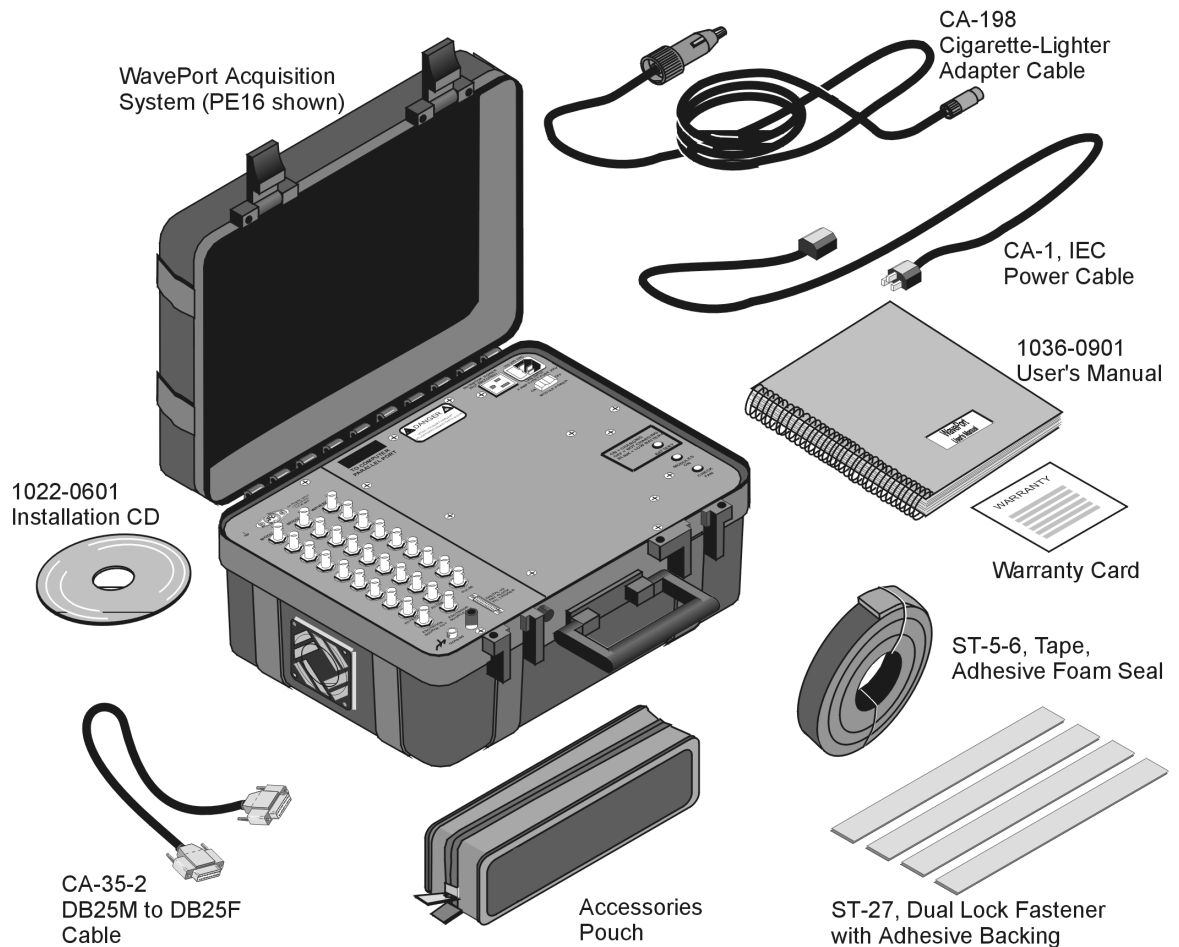

WavePort/PE, Standard Package

A typical WavePort package consists of the items depicted in the above figure. For reason of clarity, packaging materials are not shown. Note that the WavePort/PE8 (not illustrated) has two rows of BNC connectors instead of three, as depicted for the PE16 represented in the above figure. The WavePort/V series (/V8, /V16, /V24) BNC connectors and signal channels are discussed in chapters 2 and 4.

Your order was carefully inspected prior to shipment. When you receive your order, carefully unpack all items from the shipping carton and check for physical signs of damage that may have occurred during shipment. Promptly report any damage to the shipping agent and the factory. Retain all shipping materials in case the unit needs returned.

If you ordered any accessories, e.g., the WBK20A option, check the package to ensure the additional items are included.

Report any problems to your sales agent.

At this point in time, do not be concerned with the purpose of each item that was included with your shipment. Chapter 3, *System Setup* identifies the role of each item, when the purpose is not obvious.



What are WavePorts?.....2-1

What Types of I/O Signals Apply ?..... 2-2

What are WavePorts ?

WavePorts are high-speed, portable data acquisition systems housed in a rugged case. At present there are two distinct WavePort product lines; these are the **WavePort/PE** (*piezoelectric*) and **WavePort/V** (*voltage*) models.

WavePort/PE devices are pre-configured to measure voltages and transducer excitation through BNC connectors; and are ideal for applications pertaining to vibration, rotating machinery, and acoustic measurements.

WavePort/PEs measurement capabilities are as follows:

- **WavePort/PE8** - up to eight channels of voltages within $\pm 10V$ and up to 8 channels of ICP® transducer excitation (PE8)
- **WavePort/PE16** - up to eight channels of voltages within $\pm 10V$ and up to 16 channels of ICP® transducer excitation

Illustrations of the BNC sections [for both PE16 and PE8 units] are featured on the following pages.

The unit's portability makes it an excellent choice for engineers and technicians on the go. WavePort can be powered from a standard AC outlet, an external DC source, or its own internal batteries.

WavePort/V devices provide a convenient acquisition package for general-purpose voltage measurements. The "V" series offers 8, 16, or 24 channels through BNC connectors.

WavePort/V measurement capabilities are as follows:

- **WavePort/V8** - up to eight channels of voltages within $\pm 10V$
- **WavePort/V16** - up to sixteen channels of voltages within $\pm 10V$
- **WavePort/V24** - up to twenty-four channels of voltages within $\pm 10V$

Illustrations of the BNC sections [for both PE and V units] are featured on the following pages.

WavePorts can be powered from a standard AC outlet, an external DC source, or from internal batteries. Their portability makes each an excellent choice for engineers and technicians on the go.

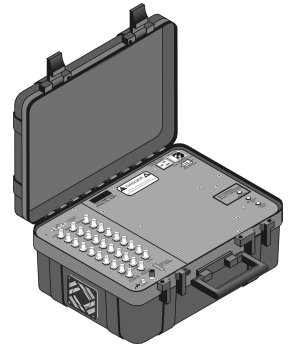

Dimensions:
470 mm wide, 369 mm deep, 191 mm high
(18.5" x 14.5" x 7.5")
Weight (excluding cables):
13 kg (28 lbs.)

WARNING



The Notebook Power receptacle is "LIVE" whenever WavePort is plugged into a live AC power source. The Module Power Switch **cannot** be used to turn this receptacle "Off."

WavePort contains no user serviceable components. Do not remove WavePort's cover plate. Lethal voltages are present which could cause serious injury or death.

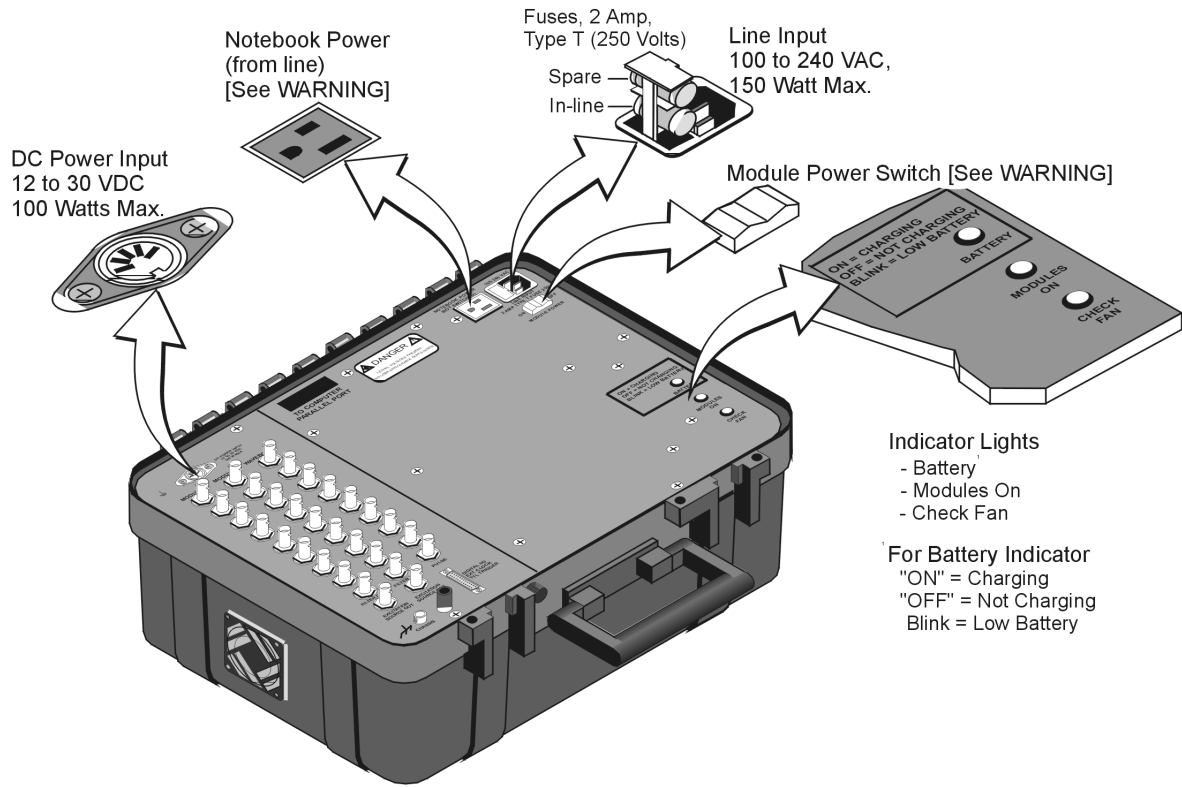

Power-Related Items

What Types of I/O Signals Apply ?

The following pages contain descriptions of signal panels for WavePort/PE and WavePort/V devices. Brief descriptions of signal types are included with each panel

More detailed information regarding signals and connections is provided in chapter 4.

WavePort/PE16

WavePort/PE16 can measure up to eight channels of voltages within $\pm 10\text{V}$; and up to 16 channels of ICP[®] transducer excitation.

The unit receives its channel-input signals through three columns of eight BNC connectors (24 channel inputs total). The columns are labeled MODULE 2, MODULE 1, and WAVEBOOK. In addition to the channel-input BNCs, WAVEBOOK contains a BNC for PULSE Trigger Input, and the two MODULES include BNCs for filter clock input (FILTER CLK. IN), and EXCITATION SOURCE OUT (see following figure).

The signal panel includes a DB25 connector for DIGITAL I/O, EXT CLOCK (external clock), and TTL TRIGGER. Connection nodes for CHASSIS (ground) and ANALOG COMMON are also provided. An illustration follows.

Module 1 and Module 2

Dynamic Signal Conditioning

CH1-1 through CH1-8 and
CH2-1 through CH2-8, respectively

- **Gain Ranges:**
x1, 2, 5, 10, 20, 50, 100, and 200
- **Input Ranges:**
5V, 2.5V, 1V,
500 mV, 250 mV,
100 mV, 50 mV,
and 25 mV peak

AC-Coupled Only

BNC shells are analog common.

See Chapter 6, WaveView and
Chapter 10, Specifications for
additional information.

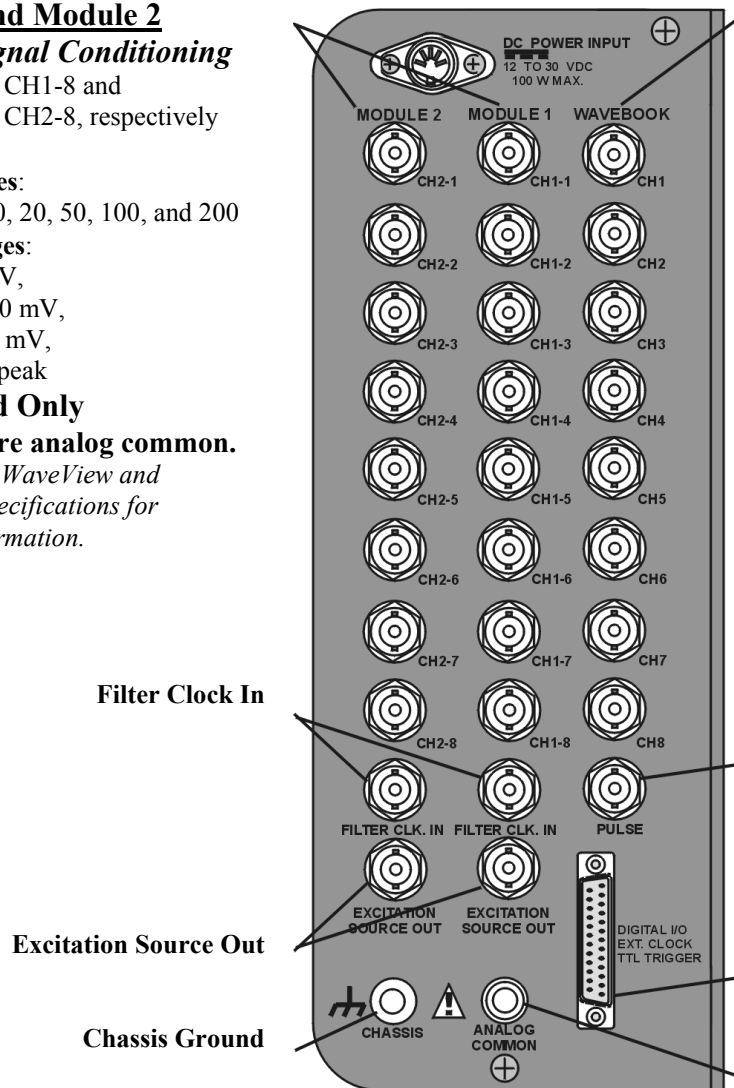

WavePort/PE16 Signal Panel

WaveBook

Analog Inputs

CH1 through CH8, Analog Inputs via
BNC Connectors.

- 16 bit resolution
- Software selectable for unipolar or bipolar operation
- **Unipolar Ranges**
0 to +10V
0 to +4V
0 to +2V
- **Bipolar Ranges**
 $\pm 10\text{V}$, $\pm 5\text{V}$, $\pm 2\text{V}$, $\pm 1\text{V}$
- Maximum Overvoltage: $\pm 30\text{ VDC}$

DC-Coupled Only,

Fully Differential

See Chapter 6, WaveView and
Chapter 10, Specifications for additional
information.

Pulse Trigger Input

- Input Signal Range: $\pm 5\text{V}$
- Input Characteristics: $75\ \Omega$
- Input Protection: $\pm 10\text{V}$ max.
- Minimum Pulse Width: 100 ns
- Maximum Pulse Width: 0.8 sec
- Latency: 300 ns

Digital I/O

External Clock

TTL Trigger

Analog Common



Reference Notes:

Additional information regarding WavePort signal connections appears elsewhere in this manual.

- Chapter 4, *Hardware and Operation Reference*, includes details regarding signal connections.
- Chapter 6, *WaveView*, includes information regarding channel configuration.
- Chapter 9 contains maintenance, intended environment, and transportation information.
- Chapter 10 provides device specifications.

WavePort/PE8

WavePort/PE8 can measure up to eight channels of voltages within $\pm 10\text{V}$; and up to 8 channels of ICP[®] transducer excitation.

The unit receives its channel-input signals through two columns of eight BNC connectors (16 channel inputs total). The columns are labeled MODULE 1 and WAVEBOOK. In addition to the channel-input BNCs, WAVEBOOK contains a BNC for PULSE Trigger Input, and MODULE 1 include one BNCs for filter clock input (FILTER CLK. IN), and another BNC for EXCITATION SOURCE OUT (see following figure).

The signal panel includes a DB25 connector for DIGITAL I/O, EXT CLOCK (external clock), and TTL TRIGGER. Connection nodes for CHASSIS (ground) and ANALOG COMMON are also provided.

Module 1

Dynamic Signal Conditioning

CH1-1 through CH1-8

- **Gain Ranges:**
x1, 2, 5, 10, 20, 50, 100, and 200
- **Input Ranges:**
5V, 2.5V, 1V,
500 mV, 250 mV,
100 mV, 50 mV,
and 25 mV peak

**AC-Coupled Only,
BNC shells are analog common.**

*See Chapter 6, WaveView and
Chapter 10, Specifications for
additional information.*

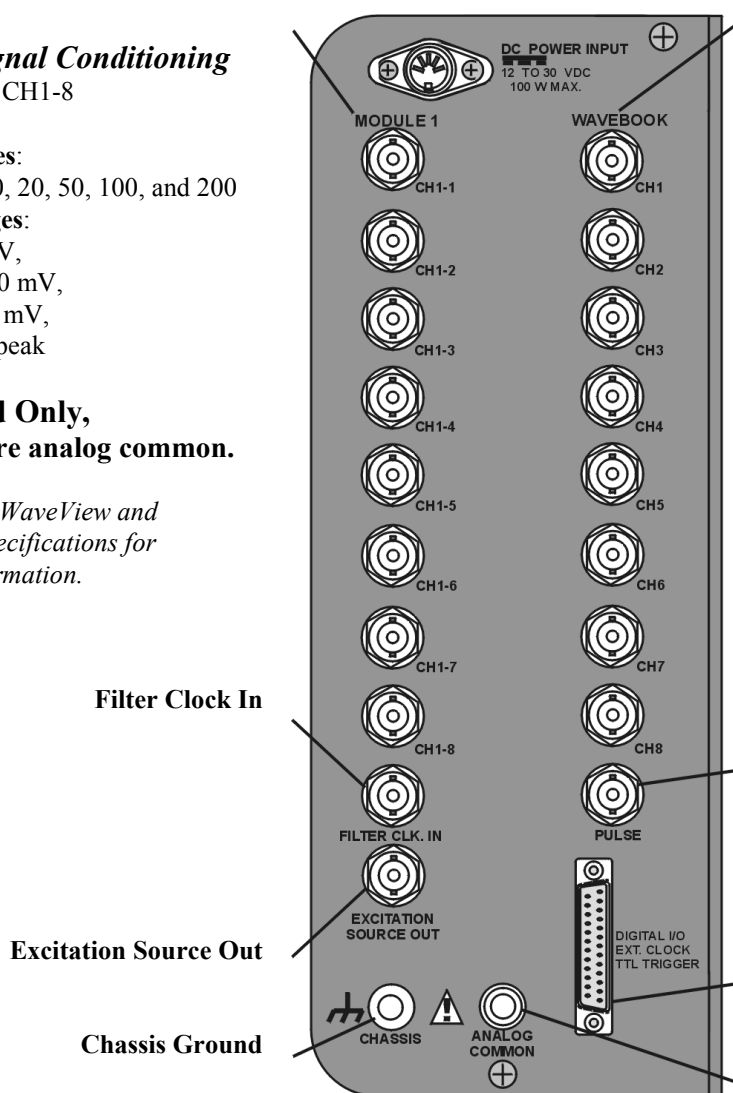

WaveBook

Analog Inputs

CH1 through CH8, Analog Inputs via BNC Connectors.

- 16 bit resolution
- Software selectable for unipolar or bipolar operation
- **Unipolar Ranges**
0 to +10V
0 to +4V
0 to +2V
- **Bipolar Ranges**
 $\pm 10\text{V}$, $\pm 5\text{V}$, $\pm 2\text{V}$, $\pm 1\text{V}$
- Maximum Overvoltage: $\pm 30\text{VDC}$

DC-Coupled Only, Fully Differential

*See Chapter 6, WaveView and
Chapter 10, Specifications for
additional information.*

Pulse Trigger Input

- Input Signal Range: $\pm 5\text{V}$
- Input Characteristics: $75\ \Omega$
- Input Protection: $\pm 10\text{V}$ max.
- Minimum Pulse Width: 100 ns
- Maximum Pulse Width: 0.8 sec
- Latency: 300 ns

Digital I/O External Clock TTL Trigger

Analog Common

WavePort/PE8 Signal Panel



Reference Notes:

Additional information regarding WavePort signal connections appears elsewhere in this manual.

- Chapter 4, *Hardware and Operation Reference*, includes details regarding signal connections.
- Chapter 6, *WaveView*, includes information regarding channel configuration.
- Chapter 9 contains maintenance, intended environment, and transportation information.
- Chapter 10 provides device specifications.

WavePort/V8

WavePort/V8 can measure up to eight channels of voltages within $\pm 10V$.

The unit receives its channel-input signals through eight BNC connectors. In addition to the channel-input BNCs, there is one BNC for PULSE Trigger Input (see following figure).

The signal panel includes a DB25 connector for DIGITAL I/O, EXT CLOCK (external clock), and TTL TRIGGER. Connection nodes for CHASSIS (ground) and ANALOG COMMON are also provided.

See Chapter 6, *WaveView* and Chapter 10, *Specifications* for additional information that includes ranges available with WBK11A, WBK12A, and WBK13A factory-installed options.

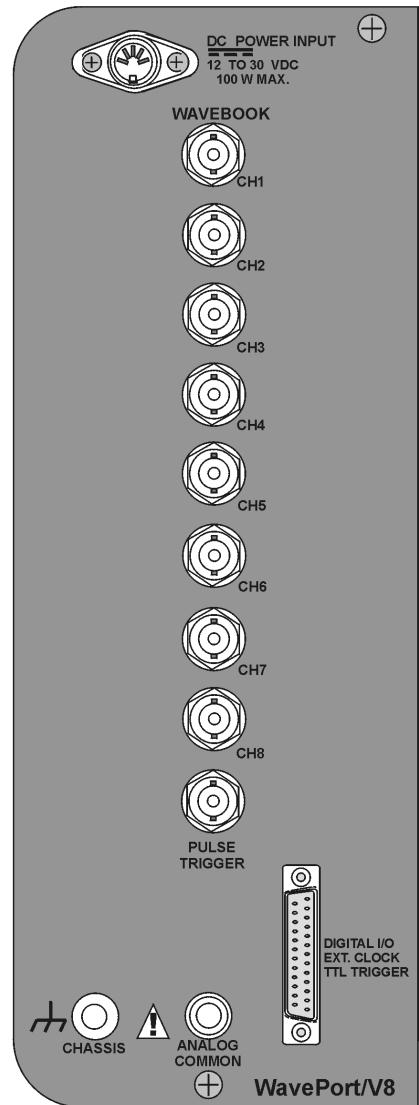

WavePort/V8 Signal Panel

WaveBook

Analog Inputs

CH1 through CH8, Analog Inputs via BNC Connectors.

- 16 bit resolution
- Software selectable for unipolar or bipolar operation
- **Unipolar Ranges**
 - 0 to +10V
 - 0 to +4V
 - 0 to +2V
- **Bipolar Ranges**
 - $\pm 10V$, $\pm 5V$, $\pm 2V$, $\pm 1V$
- Maximum Overvoltage: ± 30 VDC

DC-Coupled Only, Fully Differential

Pulse Trigger Input

- Input Signal Range: $\pm 5V$
- Input Characteristics: 75Ω
- Input Protection: $\pm 10V$ max.
- Minimum Pulse Width: 100 ns
- Maximum Pulse Width: 0.8 sec
- Latency: 300 ns

Digital I/O

External Clock

TTL Trigger

Analog Common



Reference Notes:

Additional information regarding WavePort signal connections appears elsewhere in this manual.

- Chapter 4, *Hardware and Operation Reference*, includes details regarding signal connections.
- Chapter 6, *WaveView*, includes information regarding channel configuration.
- Chapter 9 contains maintenance, intended environment, and transportation information.
- Chapter 10 provides device specifications.

WavePort/V16

WavePort/V16 can measure up to sixteen channels of voltages within $\pm 10V$.

The unit receives its channel-input signals through two columns of eight BNC connectors (16 channel inputs total). The columns are labeled MODULE 1 and WAVEBOOK. In addition to the channel-input BNCs, WAVEBOOK contains a BNC for PULSE Trigger Input (see following figure).

The signal panel includes a DB25 connector for DIGITAL I/O, EXT CLOCK (external clock), and TTL TRIGGER. Connection nodes for CHASSIS (ground) and ANALOG COMMON are also provided.

Module 1

Analog Inputs

CH1-1 through CH1-8, Analog Inputs via BNC Connectors.

- 16 bit resolution
- Software selectable for unipolar or bipolar operation
- **Unipolar Ranges**
 - 0 to +10V
 - 0 to + 5V
 - 0 to + 2V
 - 0 to +1V
- **Bipolar Ranges**
 - $\pm 10V$, $\pm 5V$, $\pm 2V$, $\pm 1V$, $\pm 0.5V$
- Maximum Overvoltage: ± 30 VDC

DC-Coupled Only, Fully Differential

See Chapter 6, *WaveView* and Chapter 10, *Specifications* for additional information that includes ranges available with *WBK11A*, *WBK12A*, and *WBK13A* factory-installed options.

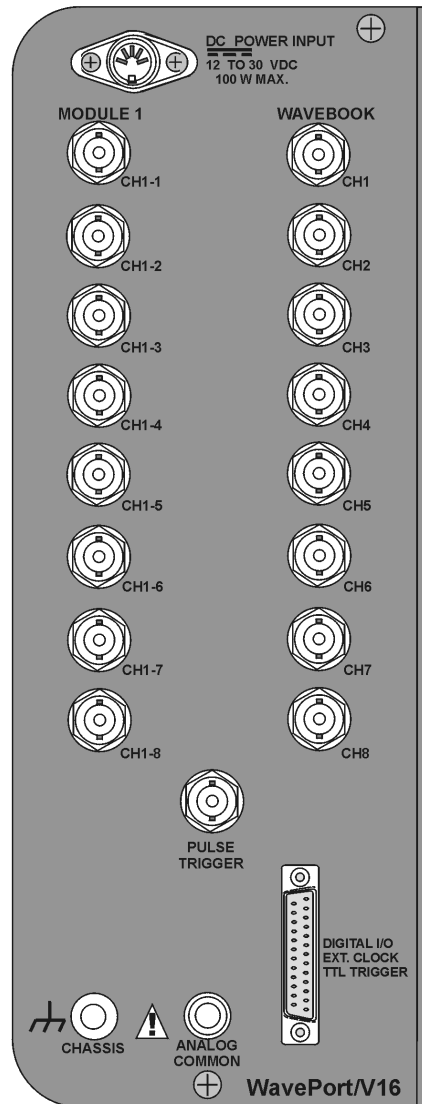

WavePort/V16 Signal Panel

WaveBook

Analog Inputs

CH1 through CH8, Analog Inputs via BNC Connectors.

- 16 bit resolution
- Software selectable for unipolar or bipolar operation
- **Unipolar Ranges**
 - 0 to +10V
 - 0 to + 4V
 - 0 to +2V
- **Bipolar Ranges**
 - $\pm 10V$, $\pm 5V$, $\pm 2V$, $\pm 1V$
- Maximum Overvoltage: ± 30 VDC

DC-Coupled Only, Fully Differential

See Chapter 6, *WaveView* and Chapter 10, *Specifications* for additional information.

Pulse Trigger Input

- Input Signal Range: $\pm 5V$
- Input Characteristics: 75Ω
- Input Protection: $\pm 10V$ max.
- Minimum Pulse Width: 100 ns
- Maximum Pulse Width: 0.8 sec
- Latency: 300 ns

Digital I/O External Clock TTL Trigger

Analog Common



Reference Notes:

Additional information regarding WavePort signal connections appears elsewhere in this manual.

- Chapter 4, *Hardware and Operation Reference*, includes details regarding signal connections.
- Chapter 6, *WaveView*, includes information regarding channel configuration.
- Chapter 9 contains maintenance, intended environment, and transportation information.
- Chapter 10 provides device specifications.

WavePort/V24

WavePort/V24 can measure up to 24 channels of voltages within $\pm 10V$.

The unit receives its channel-input signals through three columns of eight BNC connectors (24 channel inputs total). The columns are labeled [from left to right] MODULE 2, MODULE 1, and WAVEBOOK. In addition to the channel-input BNCs, WAVEBOOK contains a BNC for PULSE Trigger Input (see following figure).

The signal panel includes a DB25 connector for DIGITAL I/O, EXT CLOCK (external clock), and TTL TRIGGER. Connection nodes for CHASSIS (ground) and ANALOG COMMON are also provided.

Module 1 and Module 2

Analog Inputs

CH1-1 through CH1-8, and CH2-1 through CH2-8, respectively.

- 16 bit resolution
- Software selectable for unipolar or bipolar operation
- **Unipolar Ranges**
 - 0 to +10V
 - 0 to + 5V
 - 0 to + 2V
 - 0 to +1V
- **Bipolar Ranges**
 - $\pm 10V$, $\pm 5V$, $\pm 2V$, $\pm 1V$, $\pm 0.5V$
- Maximum Overvoltage: ± 30 VDC

DC-Coupled Only, Fully Differential

See Chapter 6, *WaveView* and Chapter 10, *Specifications* for additional information that includes ranges available with *WBK11A*, *WBK12A*, and *WBK13A* factory-installed options.

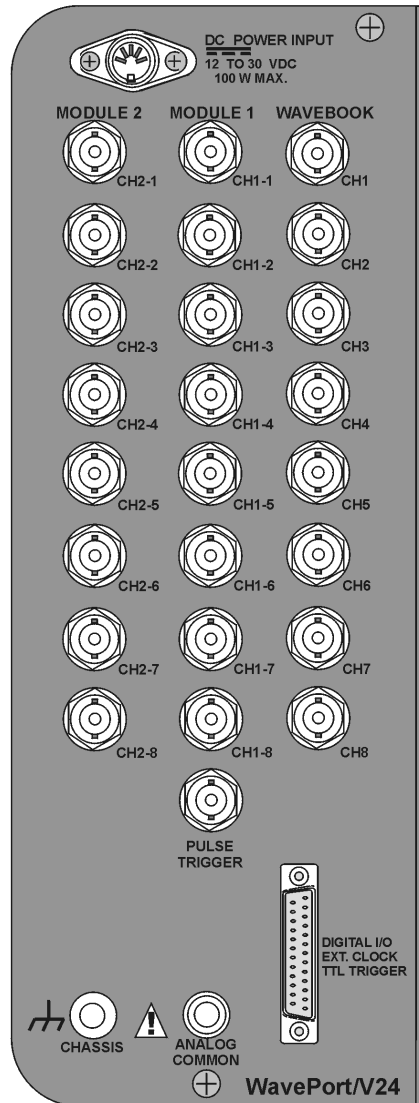

WavePort/V24 Signal Panel



Reference Notes:

Additional information regarding WavePort signal connections appears elsewhere in this manual.

- Chapter 4, *Hardware and Operation Reference*, includes details regarding signal connections.
- Chapter 6, *WaveView*, includes information regarding channel configuration.
- Chapter 9 contains maintenance, intended environment, and transportation information.
- Chapter 10 provides device specifications.

WaveBook

Analog Inputs

CH1 through CH8, Analog Inputs via BNC Connectors.

- 16 bit resolution
- Software selectable for unipolar or bipolar operation
- **Unipolar Ranges**
 - 0 to +10V
 - 0 to + 4V
 - 0 to +2V
- **Bipolar Ranges**
 - $\pm 10V$, $\pm 5V$, $\pm 2V$, $\pm 1V$
- Maximum Overvoltage: ± 30 VDC

DC-Coupled Only, Fully Differential

Pulse Trigger Input

- Input Signal Range: $\pm 5V$
- Input Characteristics: 75Ω
- Input Protection: $\pm 10V$ max.
- Minimum Pulse Width: 100 ns
- Maximum Pulse Width: 0.8 sec
- Latency: 300 ns

Digital I/O

External Clock
TTL Trigger

Analog Common



Notes

1. *Choosing a Notebook PC 3-1*
2. *Attaching the Notebook to WavePort 3-1*
3. *Connecting the Communication Cable and Notebook Power Cable 3-4*
4. *Connecting the WavePort to Power..... 3-5*
5. *Installing Software 3-5*
6. *Using the Daq Configuration Applet to Check Connections..... 3-6*
A Guide to Using the Daq Configuration Applet 3-7

1. Choosing a Notebook PC

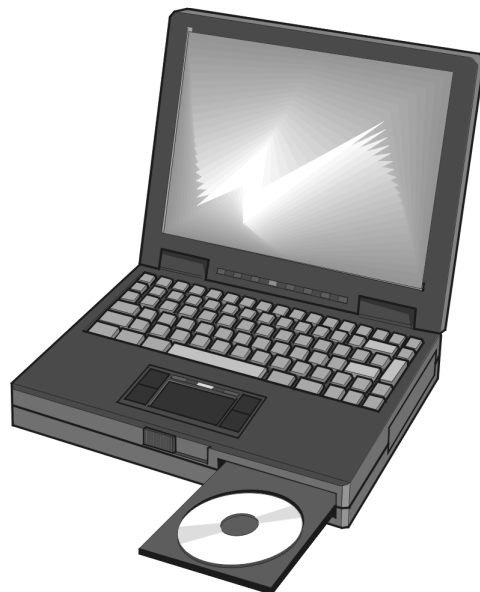

A Notebook PC provides a means of communicating with WavePort’s acquisition hardware. The Notebook you choose must meet the following requirements:

- Maximum Height (when closed): 1.5” (38 mm)
- Maximum Length: 12.75” (323 mm)
- Maximum Width: 10.19” (259 mm)
- 16MB Ram (32MB Ram recommended)
- Pentium® 90 Processor (or equivalent)
- 10 MB of Available Disk Space
- Windows Operating System (Windows95/98/NT or 2000)
- EPP (Enhanced Parallel Port) – Optional, but recommended
- Power Consumption: Not to exceed 50 Watts

2. Attaching the Notebook to WavePort

You can use the included Dual-Lock Fasteners (ST-27) to hold your Notebook PC firmly to WavePort’s cover plate.

Prior to attaching the strips, verify that WavePort’s cover plate and the bottom of the Notebook are clean. Isopropyl Alcohol swabs, or commonly available “rubbing alcohol” with clean, lint-free rags can be used to achieve a clean mounting surface.

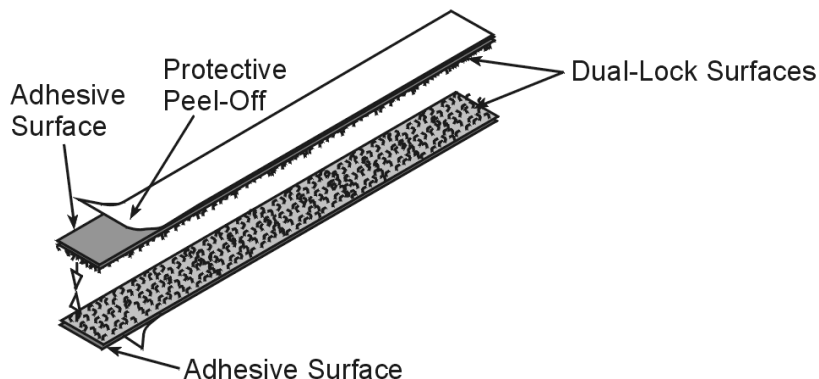

Use the following technique to ensure proper alignment of the strips.

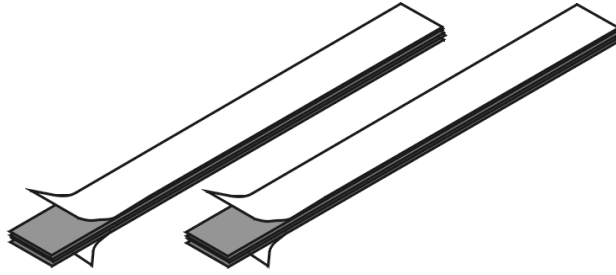

- (1) Make two mounting strips that consist of mated Dual-Lock surfaces, such that the outer surfaces of the strips are the “adhesive” sides of the strips. Note that these adhesive edges are initially covered with protective “peel-off” paper.
- (2) Trim the strips to fit the bottom surface of your Notebook PC, as needed.

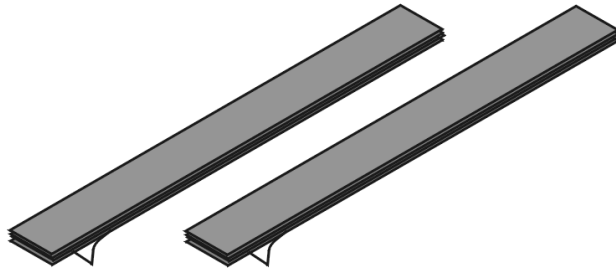

- (3) Remove the protective “peel-off” paper and attach the two strips to the bottom surface of the Notebook PC.

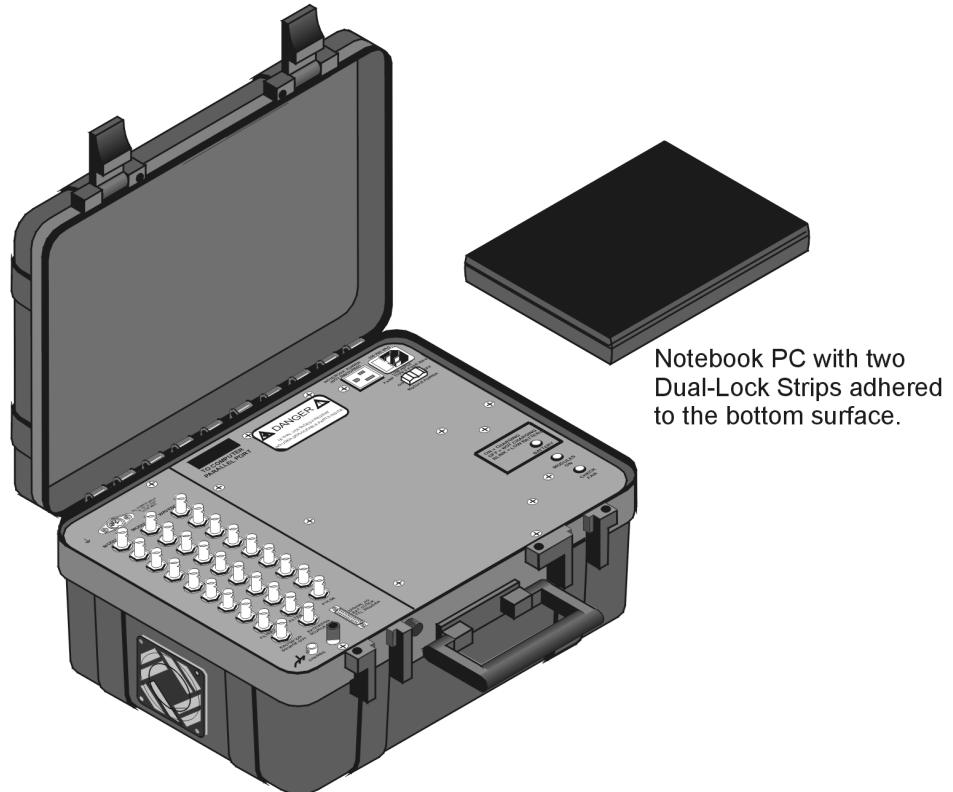

- (4) Remove the lower protective “peel-off” and position the Notebook PC onto WavePort’s cover plate.

- (5) Push firmly down on the Notebook to ensure the adhesive makes good contact. The Notebook should now be adequately secured to WavePort's cover plate.

The Notebook PC can now be easily removed from WavePort, and easily re-attached.

After securing the Notebook PC to the cover plate you should add four foam strips to the inside of WavePort's hinged lid. Cut the strips as needed to form a rectangle on the Notebook's cover (see the figure following the Caution).

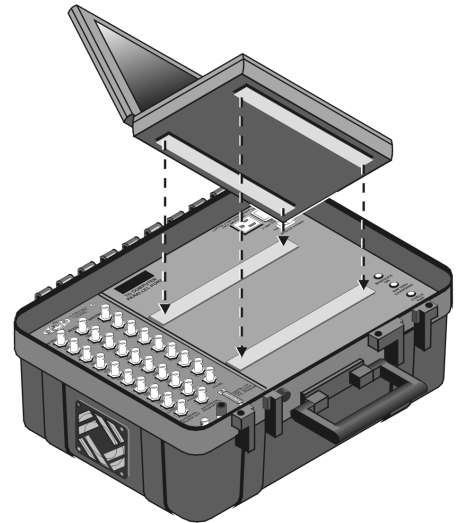

CAUTION



Forcing WavePort's cover to close on a Notebook PC that exceeds the height restriction of 1.5" (38 mm) is likely to result in damage to the Notebook PC.

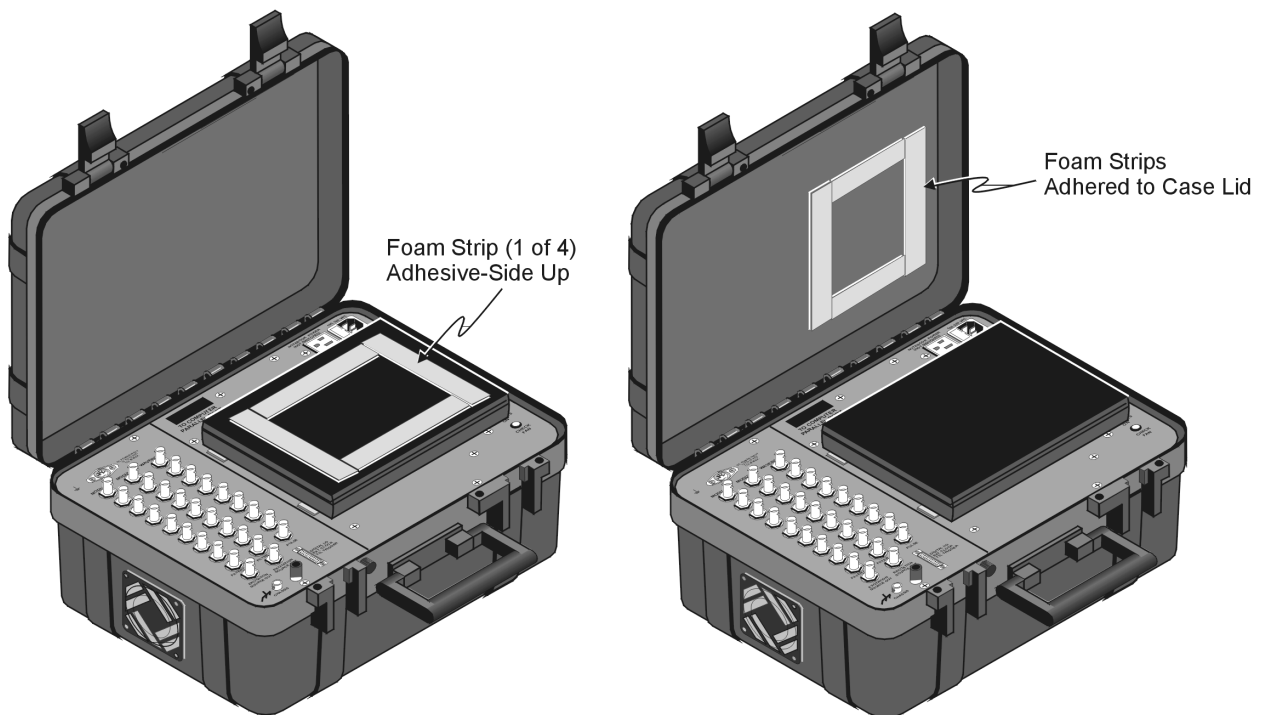

How to use foam strips (part no. ST-5-6) to pad your Notebook PC.

1. Verify that the Notebook PC does not exceed a height (when the PC is closed) of 1.5 inches (38 mm). Notebook's exceeding this dimension can be damaged when closing WavePort's cover.
2. Place four foam strips on the cover of the Notebook PC. The adhesive-side faces the WavePort's hinged cover.
3. Fully close, then reopen WavePort's cover.
4. Verify that the foam strips are attached firmly to WavePort's cover.

3. Connecting the Communication Cable and Notebook Power Cable

WavePort's communication line connects to a host PC through a 25 pin (male connector) located in a recess on WavePort's cover plate. The connector is labeled "TO COMPUTER PARALLEL PORT."

WavePort communicates with a Notebook through the PC's enhanced parallel port (EPP). An alternative is to use a WBK20A PCMCIA/EPP interface-card in conjunction with the Notebook's PC-Card port. This option is discussed in *Appendix B*.

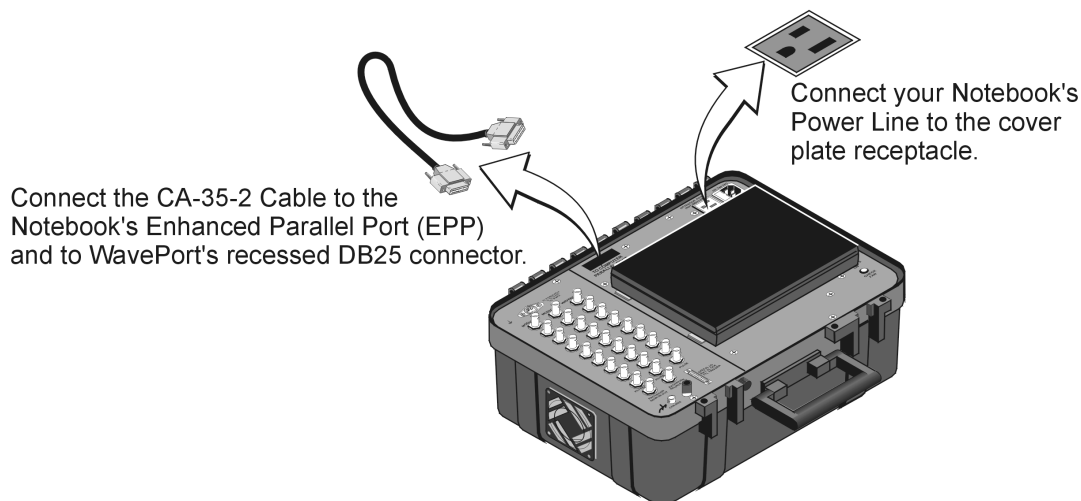

Connect the CA-35-2 Cable to the Notebook's Enhanced Parallel Port (EPP) and to WavePort's recessed DB25 connector.

Connect your Notebook's Power Line to the cover plate receptacle.

Connecting the Notebook PC to WavePort



Reference Note:

An optional WBK20A PCMCIA/EPP interface-card can be used instead of the CA-35-2 cable. WBK20A connects to the Notebook's PC-Card port. This PC-Card option is discussed in *Appendix B*.

Connect the Notebook's power line to the Notebook Power receptacle located on WavePort's cover plate. This receptacle is "live" whenever WavePort has AC line power connected to a live source. The position of WavePort's Module Power switch has no bearing on the Notebook Power receptacle.

The Notebook can be powered from the Notebook Power Receptacle [non-switched] as long as LINE INPUT power is supplied to the WavePort (as discussed in the following section). Do not plug anything into the Notebook Power Receptacle that exceeds a power rating of 50 Watts, as this could overload the WavePort.

CAUTION



Do not plug anything into the Notebook Power Receptacle that exceeds a power rating of 50 Watts. Such action could result in overloading the WavePort and blowing a fuse.

4. Connecting the WavePort to Power

WARNING



The Notebook Power receptacle is “LIVE” whenever WavePort is plugged into a live AC power source. The Module Power Switch can not be used to turn this receptacle “Off.”

WavePort contains no user serviceable components. Do not remove WavePort’s cover plate. Lethal voltages are present which could cause serious injury or death.

Although WavePort can be powered from external DC or internal batteries, we are only concerned at this point with powering the system via 100 to 240 VAC through its Line Input receptacle.

Simply connect the female-end of power cable CA-1, IEC to WavePort’s Line Input receptacle, and connect the male-end of the cable to an appropriate 100 to 240 VAC power supply.

After cable CA-1 is connected to both WavePort and the AC power supply, turn the Module Power Switch to “ON.”

Note that DC power supplies are discussed in the following chapter entitled, *Hardware and Operation Reference*.

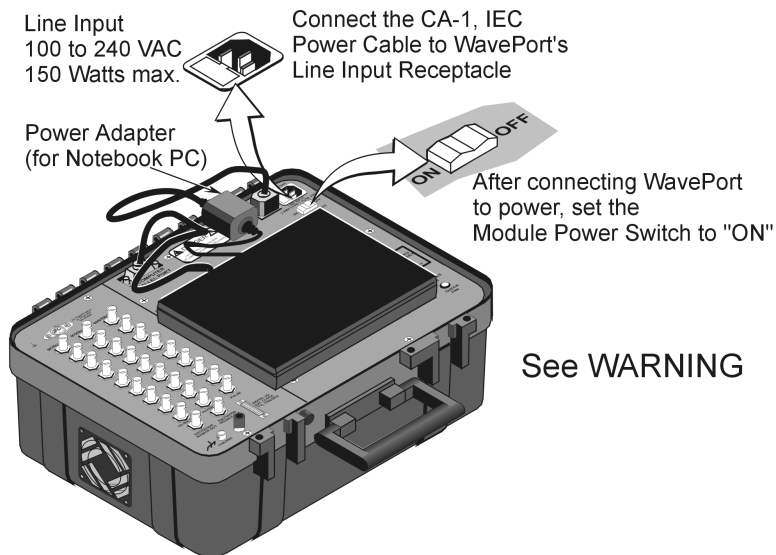

Line Input (VAC) Receptacle and Module Power Switch

5. Installing Software

Software that can be used with WavePort includes WaveView, DIAdem, DASylab, and LabVIEW. Programmers can create customized programs using DaqX Applications Program Interface (API) commands. Chapter 5 provides a brief synopsis of the software options.

For your initial setup of WavePort we recommend that you only install the following, per the steps provided below.

- P WaveBook Support 32-bit (Includes WaveView)
- P Acrobat Reader
- P DIAdem Post Acquisition Data Analysis Program



Remove any previous-installed versions of WaveBook software before installing a newer version.

Install software according to the following procedure.

1. Close all other programs. Insert CD-ROM and wait for Notebook PC to auto-access the CD.
2. On the Master Setup Screen check:
P WaveBook Support 32-bit
P Acrobat Reader
P DIAdem Post Acquisition Data Analysis Program. Note that DIAdem is detailed in Chapter 7.
3. Follow the on-screen dialog boxes to complete the installation.

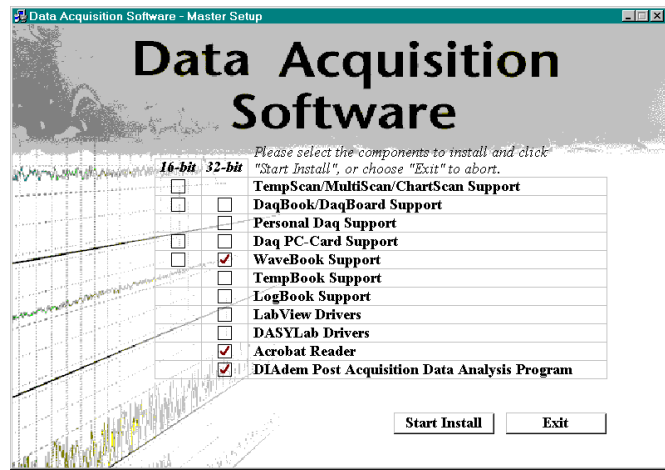

Master Setup Screen

6. Using the Configuration Applet to Check Connections

After software installation you should verify that proper communication exists between the WavePort and your Notebook. You can use the *Daq Configuration* applet to test this aspect of hardware performance. Note that the applet is automatically installed in the Windows *Control Panel* during installation of the WaveBook program group.

The *Daq Configuration* applet tests the capabilities of the PC parallel port (or WBK20/21 interface), then estimates the maximum performance, using both standard and enhanced protocols. In addition, the test verifies WavePort is connected and ready for operation.



Reference Note:

A section entitled, *A Guide to Using the Daq Configuration Applet*, begins on the following page. The section includes detailed information regarding the *Daq Configuration* applet and includes screen shots.

To run the WavePort test program:

1. Ensure WavePort is connected to the Notebook PC.
2. Verify both the Notebook and WavePort are powered.
3. Double-click on the *Daq Configuration* applet (in the Windows *Control Panel*).
4. Select the WaveBook device.
5. Click on *Properties*.
6. Click on the *Resource Test* button (within the *Test Hardware* tab).

The program performs several tests on the Notebook and WavePort and displays the results. Once communication between the Notebook and WavePort has been established you can start *WaveView* and collect data.

A Guide to Using the Daq Configuration Applet

The *Daq Configuration* applet, designed for 32-bit Windows 9x/2000/NT systems, is located in the Windows *Control Panel*. It allows you to add or remove a device and change configuration settings. The included test utility provides feedback on the validity of current configuration settings, as well as performance summaries.

Device Inventory Dialog Box

Run the applet by double-clicking on the *Daq Configuration* icon in the Windows *Control Panel*.

The *Device Inventory* dialog box will open, displaying all currently configured devices. Displayed devices show their name and an icon to identify the device type. If no devices are currently configured, no devices will appear in this field.

The four buttons across the bottom of the dialog box are used as follows:

- **Properties:** Current configuration settings for a device can be changed by first bringing up the corresponding *Properties* dialog box. Open the *Properties* dialog box by double-clicking on the device icon or selecting the device and then clicking on the *Properties* button.
- **Add Device:** The *Add Device* button is used to add a device configuration whenever a new device is added to the system. Failure to perform this step will prevent applications from properly accessing the device. Clicking on the *Add Device* button will open the *Select Device Type* dialog box.
- **Remove:** The *Remove* button is used to remove a device from the configuration. A device may be removed if it is no longer installed, or if the device configuration no longer applies.

Note: If a device is removed, applications may no longer access the device. However, the device can be re-configured at any time using the *Add Device* function described above.

- **Close:** The *Close* button may be used at any time to exit the *Daq Configuration* applet.

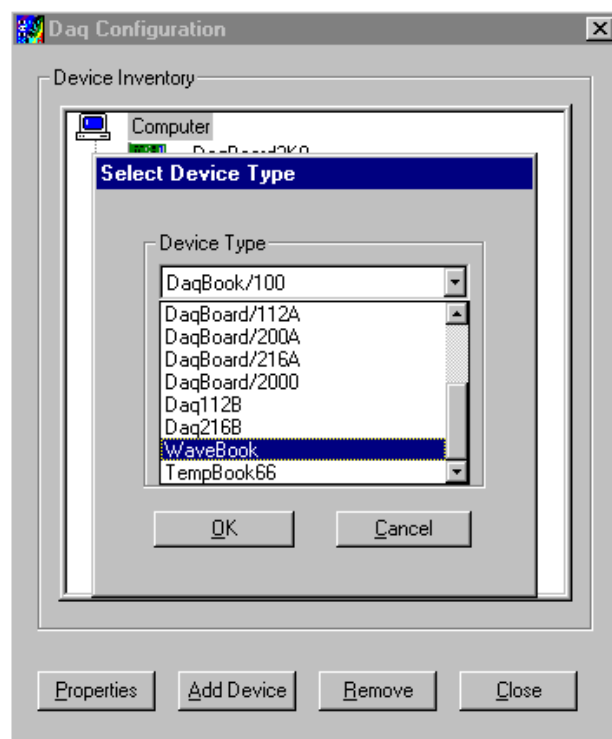

Daq Configuration - Device Inventory Dialog Box

Select Device Type Dialog Box

This dialog box opens when the *Add Device* button of the *Device Inventory* dialog box is selected.

The device type you select for configuring will appear in the main edit box. Clicking on the *OK* button will then open the *Properties* dialog box (following figure).

Note: As there is no specific “WavePort” device to select, choose “WaveBook” (see figure at right).

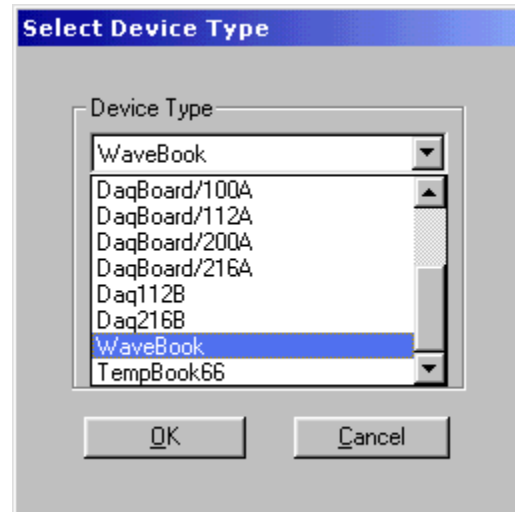

Daq Configuration - Select Device Type Dialog Box

Properties Dialog Box

This dialog box opens when the *Properties* button of the *Device Inventory* dialog box is selected, or when the *OK* button of the *Select Device Type* dialog box is selected. It displays the properties for the WaveBook device with the default configuration settings. The fields include:

- **Device Name:** The *Device Name* field is displayed with the default device name. As shown, this field can be changed to any descriptive name as desired. This device name is the name to be used with the `daqOpen` function to open the device. This name will also be displayed in the device lists for opening the device in the WaveView and WaveCal applications.
- **Device Type:** The *Device Type* field indicates the device type that was initially selected. However, it can be changed here if necessary.
- **Parallel Port:** The *Parallel Port* field is used to set the parallel port for communicating with the WaveBook.
- **Protocol:** The *Protocol* field is used to set the parallel port protocol for communicating with the WaveBook. Depending on your system, not all protocols may be available. (See following Note).

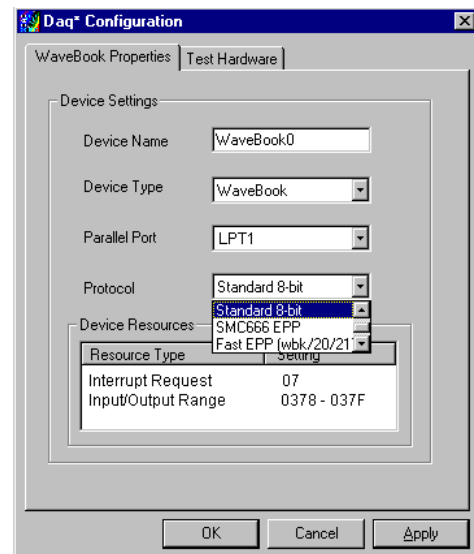

Daq Configuration - Properties Dialog Box



In regard to Protocol – If you are using a WBK20A you must select “Fast EPP (wbk/20/21)” to achieve the best performance. WBK20A is discussed in Appendix B.

- **Device Resources:** The *Device Resources* field lists settings for various resources, among them Interrupt Request, Input/Output Range, and Direct Memory Access.
- **OK:** Click on the *OK* button to store the configuration and exit the current dialog box.
- **Cancel:** Click on the *Cancel* button to exit the current dialog box without storing any changes.
- **Apply:** Click on the *Apply* button to store the configuration; or click the *Test Hardware* tab.
- **Test Hardware:** Click on the *Test Hardware* tab to test the current stored configuration for the device. This selection will open the *Test Hardware* dialog box.

Test Hardware Dialog Box

Before testing WaveBook, make sure the device has been properly installed and powered-on. Make sure the parallel port cable is firmly in place on both the WaveBook and the proper LPT port in the computer.



When testing WaveBook, if the unit does not respond within 30 seconds perform the following steps:

- 1) **reboot the system**
- 2) **upon power-up, re-open the *Daq Configuration* applet**
- 3) **select another configuration setting**
- 4) **reinitiate the test**

To test the currently stored configuration for the WaveBook device, click the *Test* button. Results should be displayed in a few seconds. The test results have two components: *Resource Tests* and *Performance Tests*.

Resource Tests. The resource tests are intended to test system capability for the current device configuration. Resource tests are *pass/fail*. Test failure may indicate a lack of availability of the resource, or a possible resource conflict.

Base Address Test. This resource test checks the base address for the selected parallel port. Failure of this test may indicate that the parallel port is not properly configured within the system. See relevant operating system and computer manufacturer's documentation to correct the problem.

Performance Tests. These types of tests are intended to check various WaveBook functions, using the current device configuration. Performance tests provide quantitative results for each supported functional group. Test results represent maximum rates the various operations can be performed. The rates depend on the selected parallel port protocol, and vary according to port hardware capabilities.

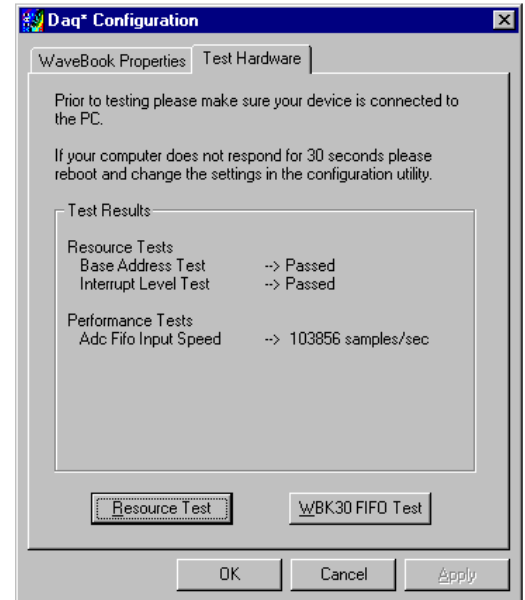

Daq Configuration - Test Hardware Dialog Box

WBK30 FIFO Test. This *performance test* checks the data-storing capabilities of the *optional*, WBK30 memory card.

When the test is completed successfully, the *Daq Configuration Test Dialog Box* indicates a passed condition.

“Passed” messages indicate you can exit the test program and run your application.



WavePort/PE Devices 4-1

Overview4-2

Basic Operation4-3

Signal Aspects4-5

WavePort/PE164-5

WavePort/PE8 4-6

WavePort/V Devices 4-7

Overview.....4-7

Basic Operation4-8

Signal Aspects4-9

Ground Connections4-10

DB25F “Digital I/O, External Clock, TTL Trigger” Connection4-11

Programmable Features4-12

Triggers4-13

Pulse Trigger4-13

Digital-Pattern Trigger4-14

Multi-channel Triggering4-14

External Clock and Counter-Timer4-15

Power Aspects4-16

Power Module Operation4-18

Charging4-19

Fuse Replacement 4-19

Factory-Installed Option Cards (for WaveBook and WBK10A-based modules) 4-20

WBK11A – Simultaneous Sample and Hold Card.....4-20

WBK12A and WBK13A Programmable Low-Pass Filter Cards4-21

WavePort’s Fan4-22

WavePort/PE Devices

Overview

The following block diagram serves to provide a general understanding of WavePort/PE devices. Detailed information regarding such items as the signal and power modules, indicator lights, and the unit fan are included later in this chapter.

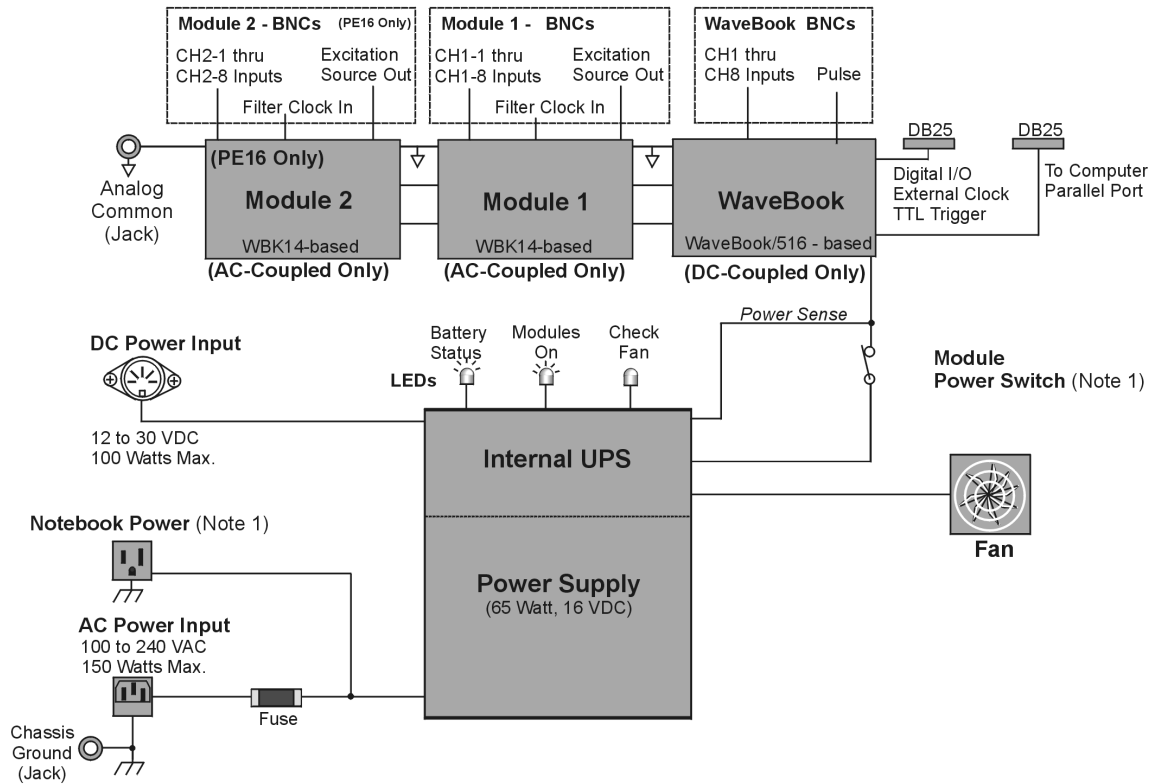

WavePort/PE, Simple Block Diagram



The Notebook Power receptacle on WavePort's cover plate is "LIVE" whenever WavePort is connected to a "live" AC power source. The Module Power Switch can not be used to turn off the Notebook Power Receptacle.

From the diagram we can see that WavePort/PE16* consists of:

- Two **Dynamic Signal Input Modules** (Module 2 and Module 1).* Both modules provide for 8 input channels (through BNC connectors), an Excitation Source Out BNC, and a Filter Clock In BNC. The dynamic signal input modules are based on WBK14 architecture.
- One **WaveBook Module**. This module provides for 8 analog channel inputs through BNC connectors and a Pulse input.
- A 65 watt, 16 VDC **Power Supply** and **Internal UPS** (Uninterruptible Power Supply) System
- Two **25-pin connectors (DB25)**. One for connecting to the Notebook's parallel port and another for connecting to Digital I/O, External Clock, and TTL Trigger signals
- Three electrical connectors: **DC Power Input**, **AC Power Input**, and **AC Auxiliary Output**
- Three Indicator Lights: for "Battery" Status, indication of "Modules On," and "Fan" On
- **Fan**, variable speed to provide system cooling

*WavePort/PE 8 has one Dynamic Signal Input Module (Module 1).

Basic Operation

WavePort/PE units integrate WaveBook/516 architecture with that of one or two Dynamic Signal Modules. The PE8 version has one dynamic module, and the PE16 has two. The architecture includes buffered input for all channels, individual instrumentation amp/channel, per-channel programmable gain, and an anti-aliasing filter. The operational description is presented separately for both the WAVEBOOK Module and the Dynamic Signal Module(s).

WAVEBOOK Module Operation

WavePort's WAVEBOOK Module includes 8 signal-input channel BNCs (CH1 through CH8). Each of these BNCs allows for **two differential signals**.

- Both signals are buffered and applied to a differential amplifier.
- The output of each differential amplifier is applied to a low pass filter.
- The signals are switched (via multiplexer) to a programmable gain amplifier.
- The amplified signals are level-shifted to the specified range. Note that **unipolar** offset (for sampling signals that are always positive) and **bipolar** offset (for signals that may be positive or negative) are available.
- The signal is switched over to the A/D converter. The converter digitizes the signal to 16 bits in 1 μ s.
- The digitized value is conditioned to compensate for gain and offset errors.
- The conditioned signal is held in a FIFO data buffer until the PC reads the data. An internal processor checks WAVEBOOK channel 1 to determine if a valid trigger event has occurred.
- The low-latency trigger is presented to a control and timing circuit for to start the acquisition after the trigger. The TTL trigger is taken directly from the digital I/O port.
- At every sample time, WavePort's Digital Signal Processor reads from the scan sequence table and accordingly programs the Control and Timing Circuit for the next sample. In regard to the next sample, the Control and Timing Circuit selects the input channel, PGA gain, level-shifter offset, and the A/D input source. It also conveys this information to dynamic signal modules (MODULE 1 and MODULE 2) and precisely controls the A/D conversion timing.
- The Digital Signal Processor makes *real-time* sample corrections using calibration information that is stored in an EEPROM.
- The digital I/O port is read and written by the processor to transfer bytes of digital data. The I/O port may be used as a simple 8-bit input port or as a 32-address byte-wide I/O port.
- Acquisition data is sent from WAVEBOOK to the Notebook PC through a high-speed EPP (Enhanced Parallel Port). The port makes use of a DB25 connector labeled "TO COMPUTER PARALLEL PORT."

MODULE 1 and MODULE 2, Dynamic Signal Module Operation

WavePort's WAVEBOOK module is connected to two dynamic analog signal input modules, for PE16; and one such module for PE8. The dynamic modules are referred to, simply, as MODULE 1 and MODULE 2. Each module provides a means of interfacing with piezoelectric transducers. These transducers include, but are not limited to, accelerometers, microphones, and force/pressure transducers.



Reference Note:

Appendix A contains information regarding the use of accelerometers.

MODULE 1 and MODULE 2 each include:

- excitation source for transducer biasing
- high-pass filter
- programmable gain amplifier (PGA)
- anti-aliasing low-pass filter
- simultaneous sample-and-hold (SSH) amplifiers

The gain, filter cut-off frequencies and current biasing levels are software programmable.

Excitation Source

A built-in, programmable excitation source stimulates dynamic systems for transfer function measurements, and serves as a reference signal for calibration. The excitation source includes a sine/random waveform generator, a programmable gain amplifier (PGA), a DC-level DAC, and a phase-lock loop. The phase-lock loop synthesizes the frequency of a fixed-amplitude sine wave and controls the bandwidth of the random signals. The PGA conditions the signal amplitude to a value between 0 V to 5 V peak. The DC level of the signal is varied independently of signal amplitude by a software-controlled DAC from -5 V to +5 V. The DC level of the excitation signal can be used to balance static loads, while the AC signal provides the dynamic excitation.

MODULE 1 and MODULE 2 provide constant current to bias ICP® transducers. Two current levels (2 mA or 4 mA) with voltage compliance of 27 V can be selected via software. The bias current is sourced through the center conductor of a coaxial lead and returns to the dynamic signal MODULE by way of the outer conductor. The output impedance is larger than 1 MΩ and presents virtually no loading effect on the transducer's output. For applications that do not require bias, the current source can be removed from the BNC input by opening a relay contact.

The Dynamic Signal MODULE's current sources are applied to (or removed from) the input in *channel-groups* of two.

For MODULE 1 these are: [CH1-1 / CH1-2], [CH1-3 / CH1-4], [CH1-5 / CH1-6] and [CH1-7 / CH1-8].
For MODULE 2 these are: [CH2-1 / CH2-2], [CH2-3 / CH2-4], [CH2-5 / CH2-6] and [CH2-7 / CH2-8].

High-Pass Filter – for MODULES 1 & 2

Every Dynamic Signal MODULE's signal input channel has two independent High-Pass Filters (HPFs) with a 3-dB cut-off frequency (F_c) at 0.1 Hz and 10 Hz. The 0.1-Hz HPF is a single-pole RC filter, and is primarily used to couple vibration signals. The 10-Hz HPF is a 2-pole Butterworth type and can be used to couple acoustic signals or attenuate setup-induced low-frequency signals that can reduce the dynamic range of the measurement (for example when using tape recorders as signal sources).

Programmable Gain Amplifier (PGA) – for MODULES 1 & 2

The High-Pass Filter removes the DC voltage from the input signal. A PGA amplifies the AC voltage with flat response up to 500 kHz. Each channel has a PGA with 8 programmable gains (1, 2, 5, 10, 20, 50, 100, and 200) and a software-controlled DAC for offset nulling. The Dynamic Signal MODULES measure only bipolar signals up to 5 V peak.

Programmable Low-Pass Filter Phase Equalizer – for MODULES 1 & 2

The first filter stage is a programmable 2-pole continuous-time low-pass filter. The phase equalizer provides more than 65 dB alias protection to the next filter stage. In addition, it fine-tunes the phase shift of the channel to optimize the phase-matching between channels. At calibration, the phase shift of each channel is measured and stored in an EEPROM that is read at configuration.

Programmable Low-Pass Anti-Aliasing Filter [and FILTER CLK. IN] for MODULES 1 & 2

Most signal alias rejection is performed by an 8-pole Butterworth filter. This filter is implemented with a switch-capacitor network driven by a programmable clock. Each channel has an independent clock that determines the filter's 3dB cut-off frequency. The switch-capacitor filter provides no attenuation at the clock frequency—hence, the need for the *continuous-time* low-pass filter.

Note: The Low-Pass Anti-Aliasing Filter can be bypassed to process signals with a bandwidth higher than 100 kHz.

FILTER CLK. IN - MODULE 1 and MODULE 2 each have a BNC labeled FILTER CLK. IN (Filter Clock In). These BNC connectors provide a path to externally control the cut-off frequency of the Low-Pass Anti-Aliasing Filter. The input waveform can be TTL or sinusoidal, with an amplitude peak of at least 500 mV. In this “External Clock” mode, cut-off frequency is set to the input frequency divided by 50.

Simultaneous Sample and Hold – for MODULES 1 & 2

All MODULE 1 and MODULE 2 channels are sampled simultaneously, after which the WAVEBOOK Module measures each output at 1 μs/channel until all channels are digitized. The time-skew between sampling on all channels is 150 ns.



When a Dynamic Signal MODULE's SSH channel is enabled, the per-channel sample rates are reduced. The rate reduction is the same as that which would occur if another channel were added. The per-channel rate (with SSH enabled) is:

1 MHz / (n+1), where *n* is the number of active channels.

Signal Aspects, WavePort/PE16

WavePort/PE16 can measure up to eight channels of voltages within $\pm 10V$ and up to 16 channels of ICP[®] transducer excitation. WavePort/PE16 receives its channel-input signals through three columns of eight BNC connectors (24 channel inputs total). The columns are labeled MODULE 2, MODULE 1, and WAVEBOOK. In addition to the channel-input BNCs, WAVEBOOK contains a BNC for PULSE Trigger Input, and the two MODULEs include BNCs for filter clock input (FILTER CLK. IN), and EXCITATION SOURCE OUT (see following figure).

The signal panel includes a DB25 connector for DIGITAL I/O, EXT CLOCK (external clock), and TTL TRIGGER. Connection nodes for CHASSIS (ground) and ANALOG COMMON are also provided.

Module 1 and Module 2

Dynamic Signal Conditioning

CH1-1 through CH1-8 and
CH2-1 through CH2-8, respectively

- **Gain Ranges:**
x1, 2, 5, 10, 20, 50, 100, and 200
- **Input Ranges:**
5V, 2.5V, 1V,
500 mV, 250 mV,
100 mV, 50 mV,
and 25 mV peak

AC-Coupled Only,
BNC shells are analog common.

See Chapter 6, WaveView and
Chapter 10, Specifications for
additional information.

Filter Clock In
(See page 4-4)

Excitation Source Out
(See page 4-4)

Chassis Ground
(See page 4-10)

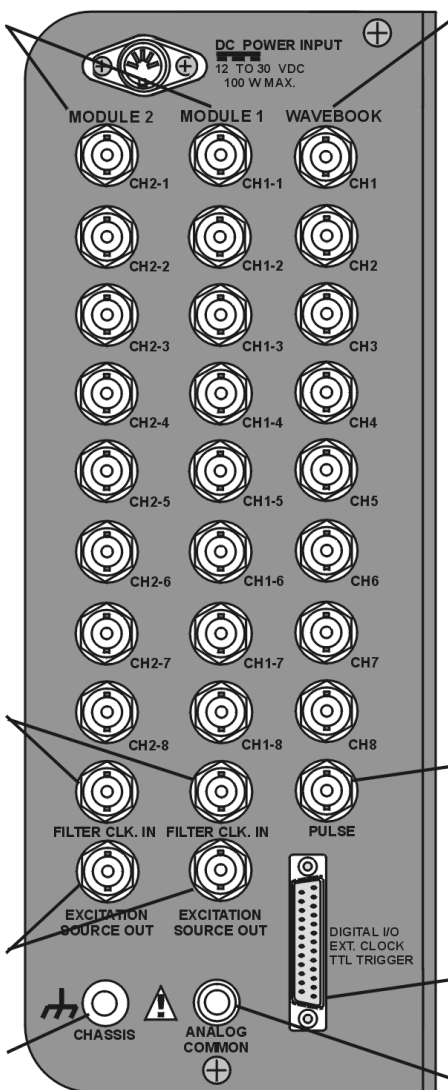

WavePort/PE16 Signal Panel

WaveBook

Analog Inputs

CH1 through CH8, Analog Inputs via
BNC Connectors.

- 16 bit resolution
- Software selectable for unipolar or bipolar operation
- **Unipolar Ranges**
0 to +10V
0 to +4V
0 to +2V
- **Bipolar Ranges**
 $\pm 10V$, $\pm 5V$, $\pm 2V$, $\pm 1V$
- Maximum Overvoltage: ± 30 VDC

DC-Coupled Only,
Fully Differential

See Chapter 6, WaveView and
Chapter 10, Specifications for
additional information.

Pulse Trigger Input (see page 4-13)

- Input Signal Range: $\pm 5V$
- Input Characteristics: 75Ω
- Input Protection: $\pm 10V$ max.
- Minimum Pulse Width: 100 ns
- Maximum Pulse Width: 0.8 sec
- Latency: 300 ns

Digital I/O (see page 4-11)

External Clock (see page 4-11, 15)

TTL Trigger (see page 4-11)

Analog Common (see page 4-10)



Reference Notes:

Additional information regarding WavePort/PE signal connections appears elsewhere in this manual. WavePort/PE8 information appears on the following page. Chapter 6, WaveView, includes information regarding channel configuration. Maintenance, intended environment, and transportation issues are discussed in chapter 9. Specifications are provided in chapter 10.

WavePort/PE8

WavePort/PE8 can measure up to eight channels of voltages within $\pm 10\text{V}$; and up to 8 channels of ICP[®] transducer excitation. The unit receives its channel-input signals through two columns of eight BNC connectors (16 channel inputs total). The columns are labeled MODULE 1 and WAVEBOOK. In addition to the channel-input BNCs, WAVEBOOK contains a BNC for PULSE Trigger Input, and MODULE 1 include one BNCs for filter clock input (FILTER CLK. IN), and another BNC for EXCITATION SOURCE OUT (see following figure).

The signal panel includes a DB25 connector for DIGITAL I/O, EXT CLOCK (external clock), and TTL TRIGGER. Connection nodes for CHASSIS (ground) and ANALOG COMMON are also provided.

Module 1

Dynamic Signal Conditioning

CH1-1 through CH1-8

- **Gain Ranges:**
x1, 2, 5, 10, 20, 50, 100, and 200
- **Input Ranges:**
5V, 2.5V, 1V,
500 mV, 250 mV,
100 mV, 50 mV,
and 25 mV peak

AC-Coupled Only,
BNC shells are analog common.

See Chapter 6, WaveView and Chapter 10, Specifications for additional information.

Filter Clock In
(See page 4-4)

Excitation Source Out
(See page 4-4)

Chassis Ground
(See page 4-10)

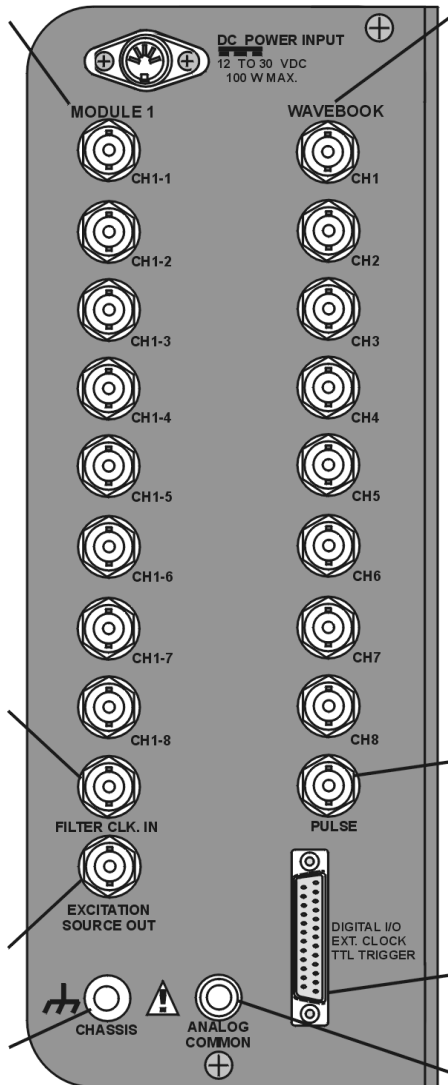

WavePort/PE8 Signal Panel

WaveBook

Analog Inputs

CH1 through CH8, Analog Inputs via BNC Connectors.

- 16 bit resolution
- Software selectable for unipolar or bipolar operation
- **Unipolar Ranges**
0 to +10V
0 to +4V
0 to +2V
- **Bipolar Ranges**
 $\pm 10\text{V}$, $\pm 5\text{V}$, $\pm 2\text{V}$, $\pm 1\text{V}$
- Maximum Overvoltage: $\pm 30\text{VDC}$

DC-Coupled Only,
Fully Differential

See Chapter 6, WaveView and Chapter 10, Specifications for additional information.

Pulse Trigger Input (see page 4-13)

- Input Signal Range: $\pm 5\text{V}$
- Input Characteristics: $75\ \Omega$
- Input Protection: $\pm 10\text{V}$ max.
- Minimum Pulse Width: 100 ns
- Maximum Pulse Width: 0.8 sec
- Latency: 300 ns

Digital I/O (see page 4-11)

External Clock (see page 4-11, 15)

TTL Trigger (see page 4-11)

Analog Common (see page 4-10)



Reference Notes:

Additional information regarding WavePort/PE signal connections appears elsewhere in this manual. WavePort/PE16 information appears on the previous page. Chapter 6, WaveView, includes information regarding channel configuration. Maintenance, intended environment, and transportation issues are discussed in chapter 9. Specifications are provided in chapter 10.

WavePort/V Devices

Overview

The following block diagram serves to provide a general understanding of WavePort/V devices. Detailed information regarding such items as the signal and power modules, indicator lights, and the unit fan are included later in this chapter.

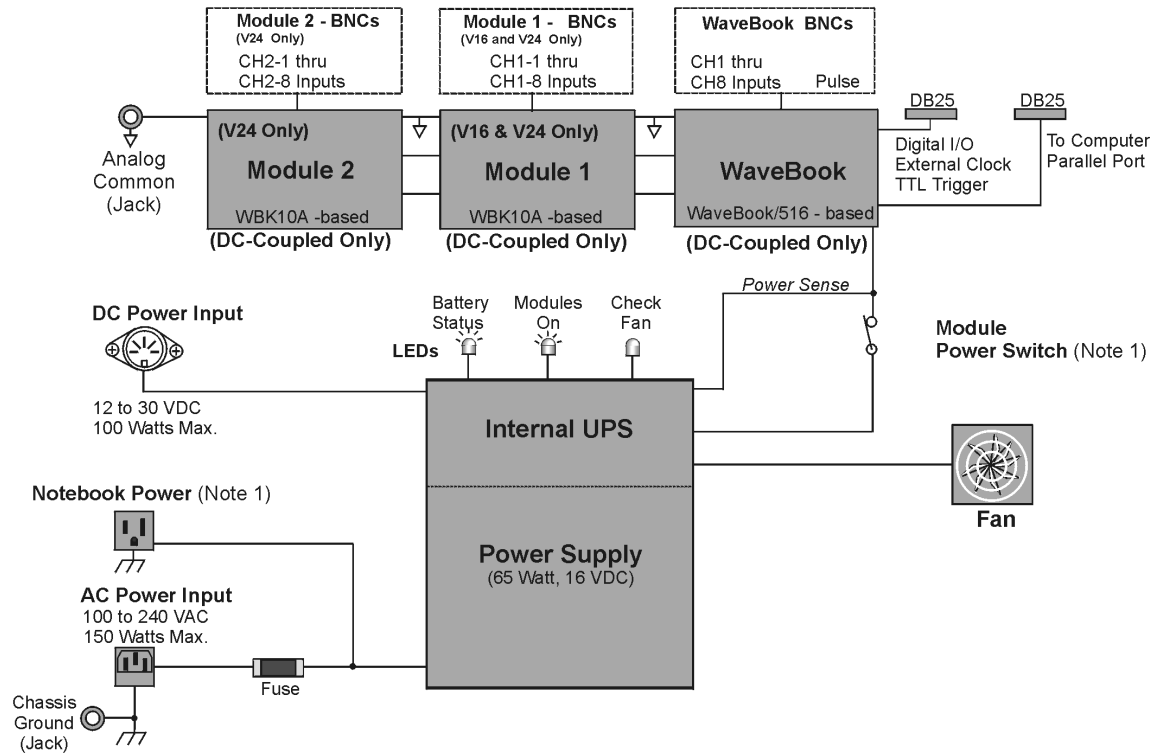

WavePort/V, Simple Block Diagram



The Notebook Power receptacle on WavePort's cover plate is "LIVE" whenever WavePort is connected to a "live" AC power source. The Module Power Switch can not be used to turn off the Notebook Power Receptacle.

From the diagram we can see that WavePort/V24 consists of:

- Two **Analog Input Modules** (Module 2 and Module 1).* Both modules provide for 8 input channels (through BNC connectors). These modules are based on WBK10A architecture.
- One **WaveBook Module**. This module provides for 8 analog channel inputs through BNC connectors and a Pulse input.
- A 65 watt, 16 VDC **Power Supply** and **Internal UPS** (Uninterruptible Power Supply) System
- Two **25-pin connectors (DB25)**. One for connecting to the Notebook's parallel port and another for connecting to Digital I/O, External Clock, and TTL Trigger signals
- Three electrical connectors: **DC Power Input**, **AC Power Input**, and **AC Auxiliary Output**
- Three Indicator Lights: for "**Battery**" Status, indication of "**Modules On**," and "**Fan**" On
- **Fan**, variable speed to provide system cooling

*In the WavePort/V product line, only **WavePort/V24** includes a WaveBook module plus two additional analog input modules (Module 1 and Module 2). **WavePort/V8** includes the WaveBook module, but has no WBK10-based modules. **WavePort/V16** includes the WavePort module and the WBK10A-based Module 1.

Basic Operation

WavePort/V units integrate WaveBook/516 architecture. In addition, the V16 unit includes a WBK10A-based analog input module; and V24 units include two WBK10A-based analog input modules. The architecture includes buffered input for all channels, individual instrumentation amp/channel, per-channel programmable gain, and an anti-aliasing filter. The operational description is presented separately for both the WAVEBOOK Module and the WBK10A-based module(s).

WAVEBOOK Module Operation

WavePort/V WAVEBOOK Modules include 8 signal-input channel BNCs (CH1 through CH8). Each of these BNCs allows for **two differential signals**.

- Both signals are buffered and applied to a differential amplifier.
- The output of each differential amplifier is applied to a low pass filter.
- The signals are switched (via multiplexer) to a programmable gain amplifier.
- The amplified signals are level-shifted to the specified range. Note that **unipolar** offset (for sampling signals that are always positive) and **bipolar** offset (for signals that may be positive or negative) are available.
- The signal is switched over to the A/D converter. The converter digitizes the signal to 16 bits in 1 μ s.
- The digitized value is conditioned to compensate for gain and offset errors.
- The conditioned signal is held in a FIFO data buffer until the PC reads the data. An internal processor checks WAVEBOOK channel 1 to determine if a valid trigger event has occurred.
- The low-latency trigger is presented to a control and timing circuit for to start the acquisition after the trigger. The TTL trigger is taken directly from the digital I/O port.
- At every sample time, WavePort's Digital Signal Processor reads from the scan sequence table and accordingly programs the Control and Timing Circuit for the next sample. In regard to the next sample, the Control and Timing Circuit selects the input channel, PGA gain, level-shifter offset, and the A/D input source. It also conveys this information to WBK10A-based modules (MODULE 1 and MODULE 2) and precisely controls the A/D conversion timing.
- The Digital Signal Processor makes *real-time* sample corrections using calibration information that is stored in an EEPROM.
- The digital I/O port is read and written by the processor to transfer bytes of digital data. The I/O port may be used as a simple 8-bit input port or as a 32-address byte-wide I/O port.
- Acquisition data is sent from WAVEBOOK to the Notebook PC through a high-speed EPP (Enhanced Parallel Port). The port makes use of a DB25 connector labeled "TO COMPUTER PARALLEL PORT."

MODULE 1 and MODULE 2, Analog Expansion Modules

Each WBK10A-based expansion module provides 8 differential analog inputs. The modules are typically equipped with a factory-installed programmable gain instrumentation amplifier (PGA). When WavePort/Vs are ordered, the customer can specify that one of the following option cards be installed in place of the standard PGA card: WBK11A, WBK12A, or WBK13A. Each of these options is discussed shortly.

Note 1: The standard WBK10A-based module comes with a pre-installed PGA card; however, WavePort orders can specify that the module is to have a WBK11A, WBK12A, or WBK13A option card in place of the PGA card.

Note 2: Refer to chapter 10 for specifications.

Hardware Setup Configuration

The analog input channel numbers are determined by the order of connection among the WaveBook module and the WBK10A-based modules (Module 1 and Module 2, as applicable.)

- Channel 0 is the WaveBook module's 8-bit digital I/O port.
- Channels 1 through 8 are the WaveBook's main channels.
- Channels 9 through 16 (CH1-1 through CH1-8) are located on the WBK10A-based Module 1 (not applicable to V8 units).
- Channels 17-24 (CH2-1 through CH2-8) are located on the WBK10A-based Module 2 (not applicable to V8 or V16 units).

WavePort	Module	Channel #
V8, V16, V24	WaveBook	0 (dig I/O)
V8, V16, V24	WaveBook	CH1-8
V16 and V24	Module 1	CH1-1 to CH1-8
V24 only	Module 2	CH2-1 to CH2-8

Signal Aspects, WavePort/V

WavePort/V24 can measure up to 24 channels of voltages within $\pm 10V$. The V8 and V16 version WavePorts measure up to 8 and 16 channels, respectively. WavePort/V24 receives its channel-input signals through three columns of eight BNC connectors (24 channel inputs total). The columns are labeled [from left to right] MODULE 2, MODULE 1, and WAVEBOOK. In addition to the channel-input BNCs, WAVEBOOK contains a BNC for PULSE Trigger Input (see following figure). Note that WavePortV8 and V16 BNC panels are illustrated in chapter 2.

The signal panel includes a DB25 connector for DIGITAL I/O, EXT CLOCK (external clock), and TTL TRIGGER. Connection nodes for CHASSIS (ground) and ANALOG COMMON are also provided.

Module 1 and Module 2*

Analog Inputs

CH1-1 through CH1-8, and CH2-1 through CH2-8, respectively.

- 16 bit resolution
- Software selectable for unipolar or bipolar operation
- **Unipolar Ranges**
 - 0 to +10V
 - 0 to + 5V
 - 0 to + 2V
 - 0 to +1V
- **Bipolar Ranges**
 - $\pm 10V$, $\pm 5V$, $\pm 2V$, $\pm 1V$, $\pm 0.5V$
- Maximum Overvoltage: ± 30 VDC

DC-Coupled Only, Fully Differential

See Chapter 6, WaveView and Chapter 10, Specifications for additional information that includes ranges available with WBK11A, WBK12A, and WBK13A factory-installed options.

- * WavePort/V16 does not include Module 2. WavePort/V8 includes the WaveBook and Pulse Trigger BNCs (but no Module BNCs).

Chassis Ground
(See page 4-10)

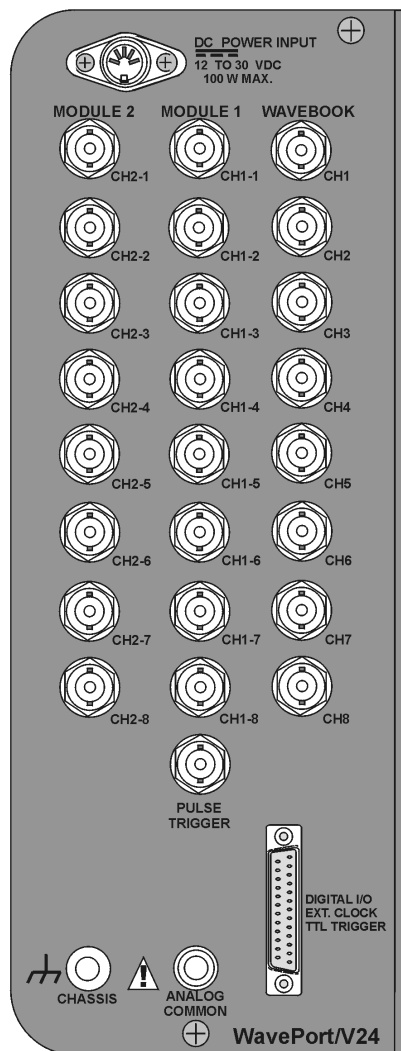

WavePort/V24 Signal Panel



Reference Notes: Additional information regarding WavePort signal connections appears elsewhere in this manual. Chapter 6, WaveView, includes information regarding channel configuration. Information regarding maintenance, intended environment, and transportation is included in chapter 9. Specifications are provided in chapter 10.

Software Setup

You will need to set several parameters so WaveView can best meet your application requirements. For software setup information, refer to the "Software Setup" section in Chapter 2, WaveBook Setup. For detailed WaveView information, refer to Chapter 5, WaveView.

WBK10A-Based Module Specifications

Specifications are provided in chapter 10.

WaveBook

Analog Inputs

CH1 through CH8, Analog Inputs via BNC Connectors.

- 16 bit resolution
- Software selectable for unipolar or bipolar operation
- **Unipolar Ranges**
 - 0 to +10V
 - 0 to + 4V
 - 0 to +2V
- **Bipolar Ranges**
 - $\pm 10V$, $\pm 5V$, $\pm 2V$, $\pm 1V$
- Maximum Overvoltage: ± 30 VDC

DC-Coupled Only, Fully Differential

Pulse Trigger Input (see page 4-13)

- Input Signal Range: $\pm 5V$
- Input Characteristics: 75Ω
- Input Protection: $\pm 10V$ max.
- Minimum Pulse Width: 100 ns
- Maximum Pulse Width: 0.8 sec
- Latency: 300 ns

Digital I/O (see page 4-11)

External Clock (see page 4-11, 15)

TTL Trigger (see page 4-11)

Analog Common (see page 4-10)

Ground Connections

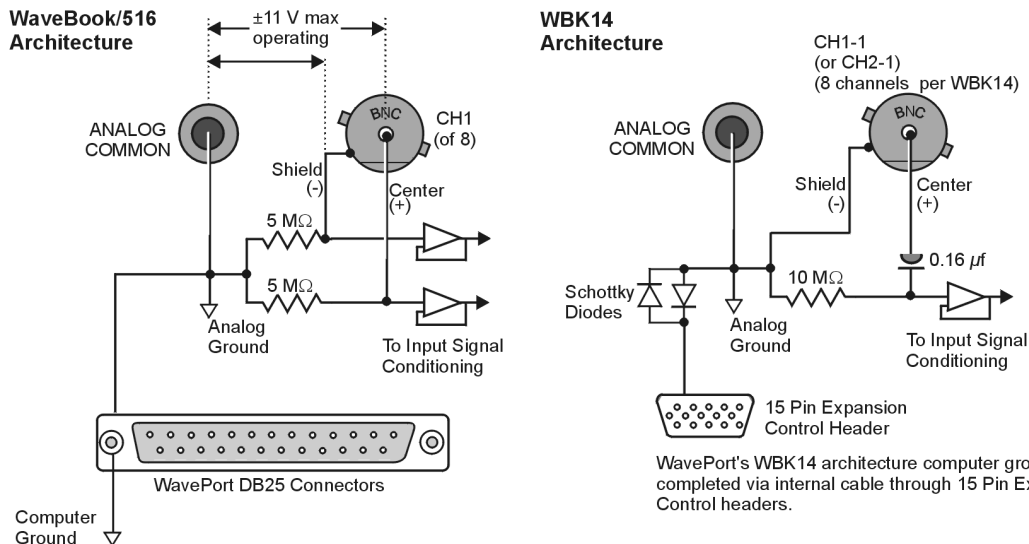

Channel Analog Input, WavePort/PE BNC Signal Connections

The center (+) and shield (-) each connect to ANALOG COMMON through a 5 MΩ resistor, resulting in a 10 MΩ differential input resistance (see above figure). WavePort's ANALOG COMMON connects to the computer power supply ground through the TO COMPUTER DB25 connector and cable.

When using a Notebook PC the computer ground could be:

- (a) *floating*, for example, when the Notebook is operating on batteries, or
- (b) *connected to vehicle ground*, for example, when using an automotive cigarette-lighter adapter in conjunction with the vehicle's battery.

Note that a pair of Schottky diodes is used in the WBK14 to clamp the ANALOG COMMON to within 0.3V of computer ground (see figure).

WavePort has an isolated power supply. Power input common is isolated from ANALOG COMMON by $>10^9 \Omega$ in parallel with 0.1 μF.



For the “WaveBook” module to correctly measure analog signals, each signal must be within ±11 volts of ANALOG COMMON. The following notes provide guidelines on how to achieve this.

Like WavePort, Notebook computers are rarely connected to AC power line ground. This is true even when these devices are plugged into AC adapters.

Connecting to ANALOG COMMON

If the computer is battery operated *and* the signal source is floating (such as an ungrounded sensor), then the internal 5 MΩ resistors *may* provide enough of a return path to ANALOG COMMON. If either the computer or the analog signal source is committed to AC power line ground, **then you will require a direct connection between the signal source and ANALOG COMMON.**

When in doubt, connect the signal source common to ANALOG COMMON.

A single-ended signal source needs to have its common connected to ANALOG COMMON.

When connecting several signal source commons to ANALOG COMMON, it is important that there is no voltage potential [between these signal source commons]. Otherwise, ground currents will circulate, leading to measurement errors.

If there is a *fixed voltage potential* between multiple signal source commons, then *only one of these signal source commons* needs connected to ANALOG COMMON. This is true *as long as* the common mode voltage of any input does not exceed ±11 volts.

Connecting to CHASSIS (Ground)

WavePort includes a CHASSIS ground node. Though it never hurts to connect the WavePort CHASSIS to a reliable ground, it is recommended that you do make this connection to ground when WavePort is ...

- ... being used in a vehicle.
- ... being used in a static-prone environment.
- ... experiencing Radio Frequency Interference (RFI) (see following note).



If WavePort experiences Radio Frequency Interference (RFI) you should:

- connect the WavePort CHASSIS to ground, and
- connect the cable-shields (of the channel inputs) to CHASSIS ground.

DB25F “Digital I/O, External Clock, TTL Trigger” Connection

The following signals are present on WavePort’s **DB25F** (25-pin, female connector) labeled “Digital I/O, External Clock, and TTL Trigger.”

- 16 High-Speed Digital I/O Lines (D0 through D15)
- TTL Trigger Input (TTLTRG)
- +15 V (pin 23), -15 V (pin 22), 50 mA max. (each)
- two +5 V (pin 19 and pin 21), 250 mA max. (total)
- External Clock (pin 20)
- two Digital Grounds (pins 24 and 25)

To sample just 16 digital input signals, connect them directly to the digital I/O data lines. D15 is the most significant bit, and D0 is the least.

The following figure depicts the DB25F connector (located on WavePort’s cover plate) and the optional CA-178 cable. The cable option is intended for External Clock and TTL External Trigger applications. Both are discussed shortly.

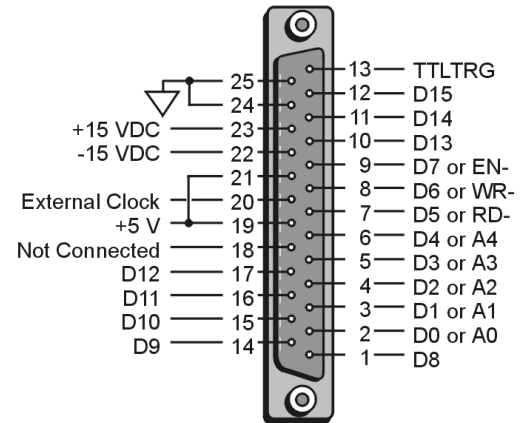

Pinout for 16-Bit Mode

Digital I/O Connections, WaveBook/516	
D0 – D15	High Speed Digital I/O data lines
TTLTRG	TTL trigger input
External Clock	16 bit mode, read/write strobe
+5 VDC	250 mA maximum
+15,-15 VDC	50 mA maximum (each)
Digital Grounds	Pins 24 and 25

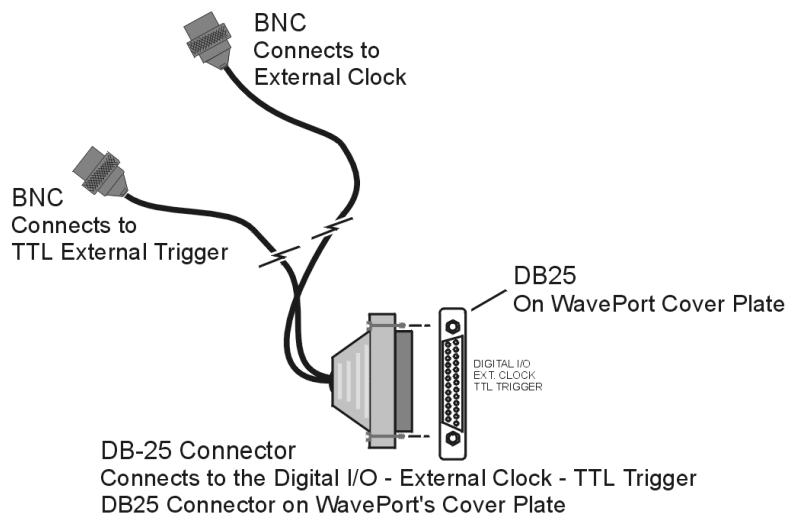

Optional Clock and External Trigger Cable (CA-178)

Programmable Features

Channels can be configured through your own custom programs or through the included *out-of-the-box* WaveView software. WaveView includes a Channel Configuration screen (following figure) that allows you to turn channels ON or OFF, select channel ranges, change channel labels, and select engineering units.



Reference Note:

Chapter 6, *WaveView* contains more detailed information. Individuals who write their own programs should refer to the readme.txt file on the install CD-ROM regarding the location of API reference material, including program examples.

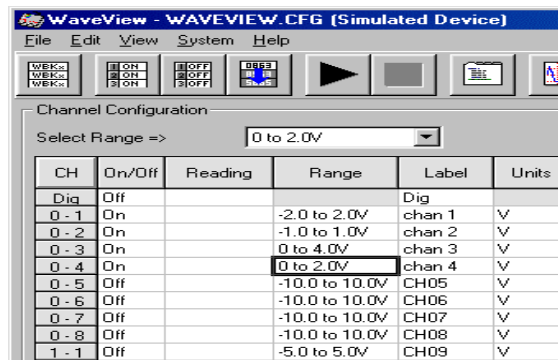

Configuring Channels from WaveView's Main Window

Selecting a Channel's Range

You can use WaveView to select a channel's range in one of two ways.

- (1) Click in a channel's *Range* cell, then select the desired range from the "Select Range" pull-down list.
- (2) Continue to double-click in the applicable channel's *Range* cell to cycle through the available ranges. Stop double-clicking when the desired range is indicated.

Selecting a Channel's Units

You can use WaveView to select a channel's units in one of two ways.

- (1) Click in a channel's *Units* cell, then select the desired units from the "Select Units" pull-down list.
- (2) Double-click in a channel's *Units* cell to cycle through the units. Note that after the **mX+b** dialog box appears you must click "OK" to continue cycling.

Note: You can use the **mX+b** equation to adjust a channel's scale and offset. You can enter user-defined units from the **mX+b** dialog box.

After completing channel configuration, you can select the *Acquisition Configuration* option from WaveView's *View* menu or tool bar. The figure to the right represents the *Acquisition Configuration* dialog box. The parameters shown are a result of the values entered below the figure. Clicking the Close button sets the acquisition parameters as the active parameters.

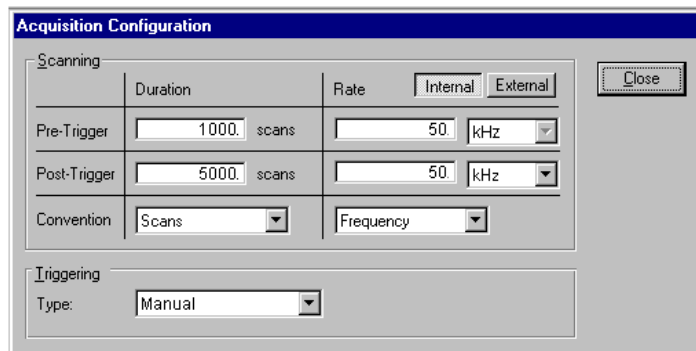

Acquisition Configuration Dialog Box

Triggering

Type: Manual

Scanning Duration

Convention: *Scans*
 Pre-Trigger: 1000 scans
 Post-Trigger: 5000 scans

Scanning Rate

Clock: *Internal*
 Convention: *Frequency*
 Pre-Trigger: 50 kHz
 Post-Trigger: 50 kHz

Triggers

This section discusses the following topics:

- **Pulse Trigger**
- **Digital-Pattern Trigger**
- **Multi-Channel Triggering**
- **External Clock and Timer**

Pulse Trigger

In addition to the standard “single-channel” *trigger-on-level* functions, the WavePort system supports **pulse trigger**. With pulse trigger, you can define both the amplitude and the duration of the pulse that will be used to trigger the acquisition. Pulse trigger can be used to detect spurious transients that can be missed by simple level triggers.

WavePort includes a BNC connector labeled “PULSE.” This connector is located on the cover plate (just below the WaveBook Channel 8 BNC).

Pulse Trigger allows the use of a high-bandwidth input for triggering, and the correlation of lower-speed waveforms with the occurrence of a high-speed pulse. You can set a pulse amplitude between ± 5 V and a pulse width in the range of 100 ns and 800 ms.

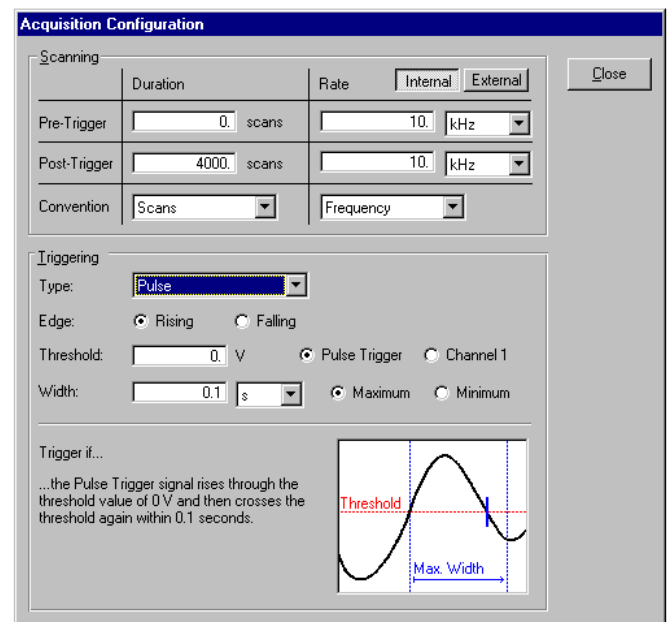

Pulse Trigger Selected

This option allows you to trigger on analog level “pulses” on either the Channel 1 input or the Pulse Trigger input. This trigger type is similar to the Channel 1 Analog trigger but places an additional time-based condition on the signal. Depending on whether the pulse width is set as a minimum or a maximum, the signal either must or must not cross the threshold again within the given amount of time. The red horizontal line (Threshold) and blue vertical lines (defining maximum width) will vary according to the parameter settings. You can specify either one or two thresholds for the level and width settings. The number of labels matches the number of thresholds and the placement follows the polarity.

- For **positive polarity**, the text is “**Rise Above... Stay Below.**”
- For **negative polarity**, the text is “**Fall Below and Stay Above.**”

Note: When used as a *maximum*, the pulse width setting can capture signal pulses. As a *minimum*, it is useful for ignoring pulses.

Digital-Pattern Trigger

This type of trigger is useful when trying to capture noise, vibrations or some other physical disturbance that occurs at a particular point in a digitally-sequenced process, such as a relay-logic-control system.

When “Digital Pattern” is selected as the Triggering *Type*, the 16-bit pattern extension appears (as indicated in the following figure). The *Condition* box allows the following choices:

Equal To (=) / Not Equal To (<>) – These options treat each digital line as a separate input to be compared to logical 1 or 0. Selecting “Equal To” triggers only on the exact pattern of 1’s and 0’s selected., while “Not Equal” triggers on all others. You can also set any of the inputs to “don’t care” (X), which excludes it from the comparison.

Greater Than (>) / Less Than (<) – These options interpret the digital inputs as a single 16-bit value and allow a threshold trigger.

The image shows a screenshot of the "Acquisition Configuration" dialog box. The "Triggering" section is expanded, showing "Type" set to "Digital Pattern". The "Condition" dropdown is set to "Equal To (=)". Below this, a 16-bit pattern extension is displayed as a row of 16 boxes, each containing a "0". Above the first and last boxes are the numbers "15" and "0" respectively. At the bottom of the pattern extension are three buttons: "All 0's", "All 1's", and "All X's (Don't cares)". The "Scanning" section above shows "Pre-Trigger" at 0 scans, "Post-Trigger" at 4000 scans, and "Rate" at 10 kHz. There are also "Internal" and "External" clock options and a "Close" button.

Acquisition Configuration Dialog Box, with Digital Pattern Extensions

Note: The top row contains a button labeled “External” for enabling the External Clock.

Multi-channel Triggering

Multi-channel triggering allows you to select a combination of analog input channels as the analog trigger, including any of its 64 optional expression channels. You can set trigger-level slope, polarity, and hysteresis for each trigger channel, then combine the trigger channels in a logical “and/or” function to define the desired trigger condition. This is made possible by Signal Digital Processing (DSP). DSP initiates sampling of the trigger channels, calibrates the incoming data, compares readings to pre-programmed trigger states, and then determines whether or not trigger conditions are satisfied.

External Clock and Counter-Timer

WavePort is capable of receiving external clock input. The external clock is useful when data collection depends on rotational speed or axial position. By synchronizing the system with an external event for correlation of data, you can collect event-dependent data instead of time-dependent data.

WaveBook/516 can receive an **external clock** input through pin 20 of the DB25 connector labeled DIGITAL I/O, EXTERNAL CLOCK, TTL TRIGGER. This enables data scanning to be correlated with an *external pulse train*. To enable the **external clock**, select “External” for the Scanning Rate in the *Acquisition Configuration Dialog Box* (see following screen shot). When the external clock is enabled, WaveBook/516 **begins a scan only after a rising edge on the TTL level occurs**. Optionally, the external clock may be divided [by a factor of 1 to 255]. This “pre-scaling” allows the user to select a reduced scan rate.

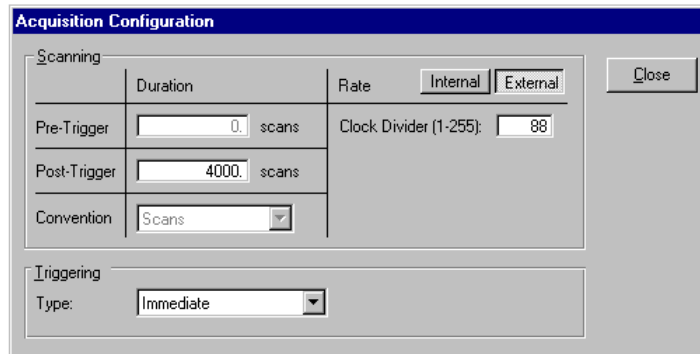

Acquisition Configuration Dialog Box with External Clock Enabled

Note: The Clock Divider can be set from 1 to 255

The WAVEBOOK module has a 32-bit **internal counter** that calculates and reports the external clock’s period. The counter can be read with each scan of the analog data. This is often beneficial in later analysis, when there is a need to correlate physical phenomena with speed.

The counter channel actually consists of two independent channels (CtrLo and CtrHi). These can be turned “On” in the *Channel Configuration Spreadsheet*. When enabled, the low (CtrLo), then high (CtrHi) words of the counter will be configured in each scan. Note that the spreadsheet’s **Units** column can be used to view a predefined period in units of seconds, ms, or μ sec.

WaveView can be configured to read *only the low word* of the counter data (CtrLo: “On,” CtrHi: “Off”). This decreases the minimum scan period by 1 usec. This *LoCtr only option* can be used *only* when the external clock frequency is greater than 305 Hz ($20,000,000 \text{ MHz} / 65536$). Note that WaveView does not enforce this.

Power Aspects

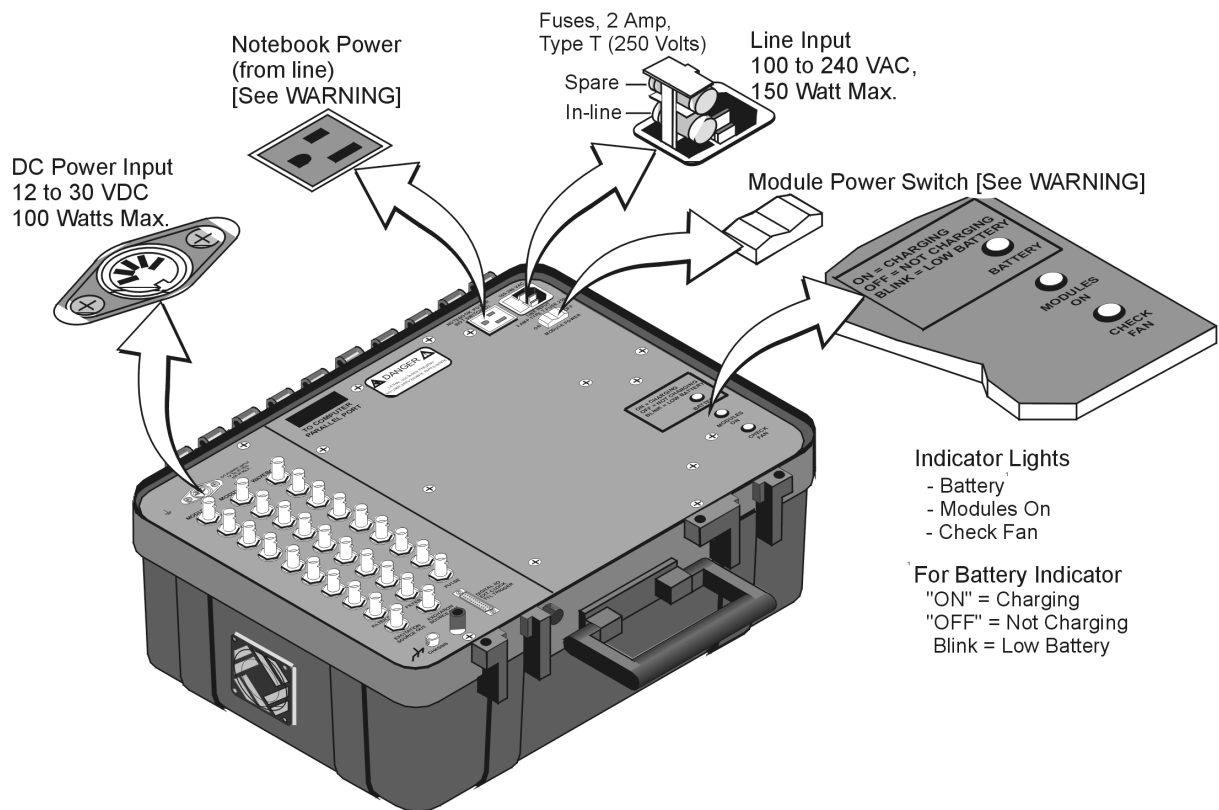

WavePort's Power-Related Aspects

WARNING



The Notebook Power receptacle is "LIVE" whenever WavePort is plugged into a live AC power source. The Module Power Switch can not be used to turn this receptacle "Off."

WavePort contains no user serviceable components. Do not remove WavePort's cover plate. Lethal voltages are present which could cause serious injury or death.

WavePort can receive power from one of three sources:

From External AC: Connect the AC power cord to the LINE INPUT (100 to 240 VAC) receptacle on WavePort's cover plate; then plug the cord into a standard AC outlet. After the power cord is properly connected, turn WavePort's Module Power Switch "On."

Note that the external AC power is also used to supply the Notebook power receptacle. As long as AC power is supplied to WavePort, the Notebook receptacle will have power. The Module Power Switch is not in line with the receptacle and cannot be used to turn it off.

From External DC: Connect the DC power cord to the DC Power Input DIN5 connector on WavePort's cover plate. Connect the other end of the cable to a 12 to 30 VDC source, such as an automotive electrical system. After the power cord is properly connected, turn WavePort's Module Power Switch "On." Note that a CA-198 cable can be used to link a WavePort to a vehicle battery via a connection from WavePort's DIN5 connector to the vehicle's cigarette lighter.

From Internal Sealed Gel-Pack Batteries. When the Module Power Switch is "On," internal gel-pack batteries will supply power to modules if insufficient power is available from an AC or other another DC source. Fully charged batteries will provide approximately 30 minutes of operation.

WavePort's self-contained power module can power the unit in portable, or "in-vehicle" UPS applications [both 12 and 24 Volt DC systems]. The power module provides clean and uninterrupted operating power for reliable data acquisition in a vehicle. This can be:

- Before (and during) connection to the vehicle
- Prior to engine/generator start
- During engine start-up (battery sag due to the high-current demand of starter motor and solenoid)
- After engine turn off
- When (and after) disconnecting from the vehicle

The power module contains two rechargeable gel-pack batteries, associated charging circuits, and current indicators. The charging process is relatively fast, and extreme temperature performance is good.

Main and auxiliary power input comes from 12 to 30 VDC via WavePort's DIN5 connector, labeled: DC POWER INPUT, and located on WavePort's cover plate. Lines from the DIN5 pins connect to WavePort's internal power module.

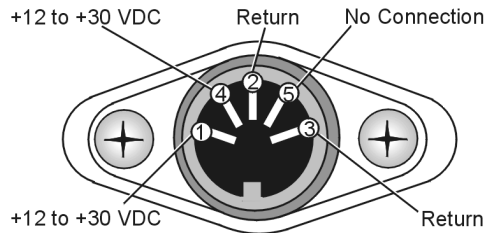

*DC Power Input
DIN5 Connector on WavePort's Cover Plate*



A CA-198 (10 foot-long power-adapter cable) can be used to power WavePort from a vehicle. The CA-198 can link WavePort's DIN5 connector to a vehicle's cigarette lighter.

The 5-pin DIN connector is rated at a maximum load of 5 Amps.



CA-198 Power-Adapter Cable



For trouble-free operation, you must fully charge the batteries before use. Charged battery runtime depends on the load and on the mode of operation.

When useful battery power is nearly depleted, a **Beeper** sounds to provide warning. A few minutes after the beeper begins sounding, an internal cutoff circuit disconnects the load from the battery. This feature protects the batteries from "deep-cycle" damage.

As indicated by the following block diagram, automatic *temperature compensated* charging circuits recharge the internal batteries. The charging process is safe and relatively quick. The battery status LED lights solid to indicate a charge is in progress. If this LED is blinking, the batteries are at a low energy level, but are not yet being charged.

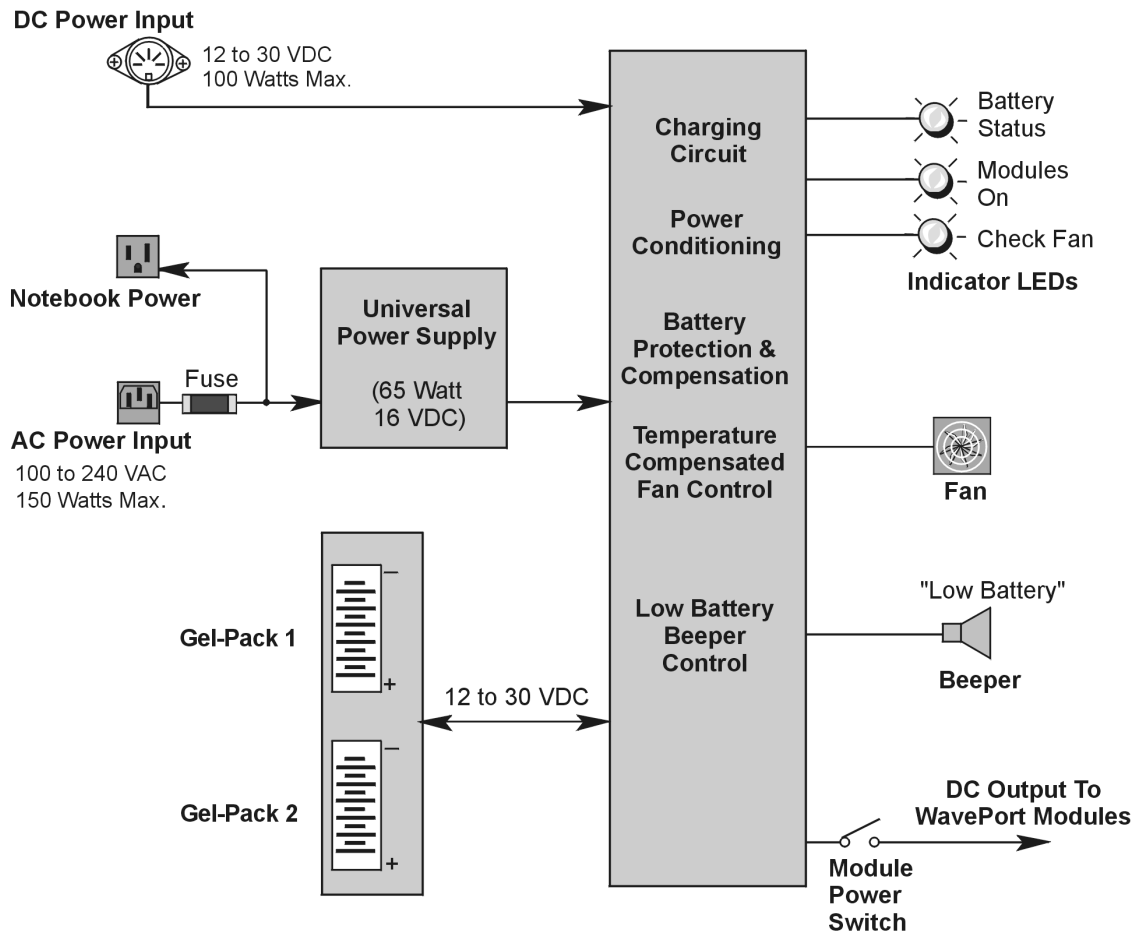

WavePort Power Distribution, Simplified Block Diagram

Power Module Operation

LED Indicators: WavePort's power module interacts with three LEDs located on WavePort's cover plate.

Indicator LEDs (Located on WavePort's Cover Plate)*	
BATTERY	<p>Lights solid when the internal batteries are being fast-charged at a rate of 0.2 amp/cell or greater.</p> <p>Off when no charge is in progress.</p> <p>Blinking indicates low battery level. Note that the beeper sounds at low battery level.</p>
MODULES ON	Lights when power is being supplied to the WavePort modules.
CHECK FAN	Verify the fan is operating properly and that the vents are not obstructed. The CHECK FAN LED lights when activated by the internal temperature sensor. When this LED is lit, a possible overheating condition exists.
* Located on WavePort's Cover Plate. Visible only when WavePort's lid is open.	

Charging

In general, lead-acid batteries [and comparable gel-pack batteries] require charging at 120% of drain energy (e.g., the 4 A-hr power module requires a charge equal to, or greater than 5 A-hr). Charging times vary; but times of 4 to 5 hours are typical for a battery that is fully discharged at the time a charge commences.

If WavePort's modules are powered-on, then the charge rate is reduce and a charge time of approximately 15 hours will be required to return the power module's batteries to a full-charge state.

Follows these simple steps to ensure the best charge possible.

1. Turn the WavePort's **Module Power Switch** to **OFF**.
2. Ensure WavePort is connected to a suitable **AC-line power source**. Note that the unit will accept AC power in the voltage range of 90 to 260 VAC, and within the frequency range of 50-400 Hz.
3. **Allow the charge to run until the BATTERY indicator LED goes out**. The BATTERY indicator will be lit solid while the batteries are being fast-charged at the 0.2 amp/cell rate.



To ensure the best charge possible:
always use the AC line power to charge WavePort's batteries.

CAUTION



DC Voltage applied to WavePort must not exceed 30 VDC.

Fuse Replacement

If there is no power available at WavePort's Notebook Power receptacle, and WavePort is plugged in to a "live" 100 to 240 VAC Power Source, it is likely that the AC in-line fuse has blown. You can replace the fuse as follows:



Fuse Access Closed

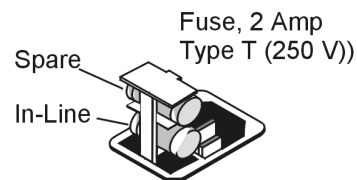

Fuse Access Opened

Two Views of WavePort's AC Line Power Receptacle

Note: If you do not need WavePort's modules powered, position the Module Power Switch to "Off" to conserve battery power while the unit is disconnected from the AC power supply.

1. Remove WavePort's power cord from the AC Power Supply and from the AC Line Receptacle on WavePort's cover plate.
2. Open the Fuse Access on the AC Line Receptacle (see figure).
3. Remove the lower "In-Line" Fuse.
4. Verify that the fuse is blown.
If the fuse is not blown, and your AC Power Supply is known to be reliable, promptly notify your service representative.

5. Position a new 2 Amp, Type T, 250V fuse (or the Spare fuse) in the In-Line position (see figure).
Note: It is recommended that you keep a Spare fuse in the holder.
6. Push the Fuse Access down such that the new fuse is place in-line.
You can now return the WavePort to normal operation.

Factory-Installed Option Cards

(for WaveBook and WBK10A-based modules)

WBK11A - Simultaneous Sample & Hold Card

WBK11A is a simultaneous sample-and-hold card (SSH) that can be factory-installed in WavePort, in place of the standard PGA card. The WBK11A option can simultaneously sample 8 channels. It can be installed in WavePort's WaveBook, as well as in the WBK10A-based modules. The WaveBook portion of WavePort controls the WBK11A.

Note that the WBK11 allows concurrent (<150 ns) capture of multiple input channels and virtually eliminates channel-to-channel time skewing.



When using WavePort with an SSH channel enabled, the per-channel sample rates are reduced. The rate reduction is the same as that which would occur if another channel were added. The per-channel rate (with SSH enabled) is:

1 MHz / (n+1), where *n* is the number of active channels.

The WBK11A SSH card can accommodate higher gains than the main unit because its gains are fixed for each channel prior to the acquisition. Each channel may be set, in software for ranges shown in the table. All channels equipped with SSH circuitry are sampled simultaneously as a system.

Hardware Setup

Configuration

All WBK11A configurations are controlled by software. There are no hardware settings.

Installation

For the WavePort product lines, WBK11A cards are only to be installed at the factory. Customer installation or removal of internal WavePort components will result void of your product's warranty.

Software Setup



Reference Note:

For software setup information, refer to the "Software Setup" section in chapter 2.
For detailed *WaveView* information, refer to chapter 5.

WBK11A - Specifications

Specifications are provided in Chapter 10.

WBK12A and WBK13A - Programmable Low-Pass Filter Cards

The WBK12A and WBK13A are 8-channel programmable low-pass filter cards for use with 1-MHz WaveBook data acquisition systems, including WavePort. These cards, when ordered as an option, are factory-installed into WavePort's WaveBook module, the WBK10A-based Module 1, and/or the WBK10A-based Module 2, as applicable.

Note that the Module 1 and Module 2 expansions provide programmable low-pass filtering over all channels. All WBK12A and WBK13A low-pass filters and cutoff frequencies are configured via software.

Note: WBK13A is like the WBK12A, except in that the WBK13A has the additional capability of simultaneous sampling all of the module's channels. If multiple WBK13A cards are installed within one system, all channels will be sampled within 100 ns of each other.

Features of the WBK12A and WBK13A include:

- **Low-Pass Filters.** Each card provides 8 input channels, arranged in two 4-channel banks; the filter and cutoff frequency configurations are applied per bank. The cards' filters can be configured as either an 8-pole elliptic filter with cutoff frequencies of 400 Hz to 100 kHz, or an 8-pole linear-phase filter with 400 Hz to 50 kHz cutoff frequencies.
- **Cutoff Frequencies.** The WBK12 and WBK13 provide 747 discrete cutoff frequencies that can be determined exactly by the formula $F_c = 300 \text{ kHz}/N$; where the integer $N = 3 \text{ to } 750$. Alternatively, you can configure any channel to bypass the programmable filter entirely, resulting in a 1-pole low-pass filter at about 500 kHz.
- **Programmable-Gain Amplifiers.** The cards' programmable-gain instrumentation amplifiers can be software selected to various gains on a per channel basis. The gains are set prior to the beginning of an acquisition sequence and cannot be changed during an acquisition.

Note: WBK12A and WBK13A gain specifications are provided in Chapter 10.

- **Simultaneous Sample-and-Hold (SSH) (WBK13A only).** In addition to the filtering capability of the WBK12A, the WBK13A provides per channel SSH. Simultaneous sampling of all channels occurs at the start of a scan sequence.



When using WaveBook with an SSH channel enabled, the per-channel sample rates are reduced. The rate reduction is the same as that which would occur if another channel were added. The per-channel rate (with SSH enabled) is:

$1 \text{ MHz}/(n+1)$, where n is the number of active channels.

Hardware Setup

Configuration

The WBK12A and WBK13A configurations are controlled by software. No hardware settings are required.

Installation

For the WavePort product lines, WBK12A and WBK13A cards are only to be installed at the factory. Customer installation or removal of internal WavePort components will void of your product's warranty.

Software Setup



Reference Note:

For software setup information, refer to the "Software Setup" section in Chapter 2. For detailed *WaveView* information, refer to chapter 5.

WBK12A and WBK13A - Specifications

Specifications are provided in Chapter 10.

WavePort's Fan

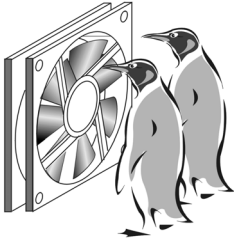

Please don't block the fan or the vents.

WavePort components are air-cooled and *cooling to ambient* occurs as long as the surrounding environment is cooler than the unit. When the unit becomes too warm for ambient cooling, a temperature sensor signals the fan to run.

The fan's speed varies, depending on WavePort's internal temperature. In cooler environments the fan operates at lower speeds, thus reducing audible noise. Typically, if the modules are powered on, or if the batteries are charging, the fan will run.

Note that long term trickle charging is accomplished without the use of the fan.

To maintain sufficient cooling, it is important to keep the fan and vents free of obstruction.

If the CHECK FAN indicator LED comes on you should:

- 1) Check WavePort's cover plate. If the plate feels hot, turn the Module Power Switch to OFF.
- 2) Verify that the fan is running. If not, proceed to step 6.
- 3) Verify that the fan and the casing vents are not obstructed.
- 4) Remove obstructions to the fan and vent, if applicable.
- 5) If the fan's filter appears dirty or clogged, replace it as described in Chapter 9.
- 6) If there appears to be a problem with overheating or with the fan, contact your service representative.

This section provides a brief summary of software that can be used with WavePort. References to relevant documentation are included. Software discussed in this chapter includes:

- **WaveView™** *Out-of-the-Box™* Software
- **DIAdem®** *Out-of-the-Box™* Software
- **DASYLab®** Icon-Based Software
- **DaqX** Language Drivers for Programmers

WaveView™ *Out-of-the-Box™* Software

WaveView is a graphical Windows-based program for use in WaveBook applications. This program allows users to acquire data for immediate viewing or for storage to the PC's hard disk. *WaveView*'s "spread-sheet" style interface makes it easy to set up your application quickly and begin acquiring data within minutes of completing hardware connections. No programming knowledge is required.

From *WaveView* you can:

- Set up all analog or digital input parameters.
- Acquire and save data to disk.
- View the acquisition in real-time.
- Send data to other Windows applications, such as spreadsheets and databases.
- Launch *DIAdem*, an independent application, to view file data that was recorded by *WaveView*.

WaveView is detailed in Chapter 6.

DIAdem® *Out-of-the-Box™* Software

The basic *DIAdem-View* application is included as part of the *Out-of-the-Box* application software. The program's interactive graphics makes it possible to examine large data files at high speeds. Zoom and cursor features permit the viewing of small details in the collected data.

Add-on software modules can be used to enhance the basic *DIAdem-View*. The add-on options provide additional data-viewing and data-management tools, along with data analysis and report generation functions.

DIAdem is detailed in Chapter 7.

DASYLab®, Icon-Based

Most WavePort users do not need to go beyond *WaveView* and *DIAdem* to satisfy their application needs. However, for individuals who want to customize their application the "Icon-Based" *DASYLab* program offers a great degree of flexibility. *DASYLab* configurations make use of icons and spreadsheets, but unlike many other graphic program environments, *DASYLab* applications can be up and running in a matter of a few hours or days, without the use of expensive training courses.

DASYLab's display formats include: Chart Recorders, Analog and Digital Meters, Bar Graphs, Y/t and X/Y charts, and status lamps. Other features include limit markers, trend indicators, zooming, 3-D waterfall displays, and the ability to display multiple waveforms in one chart.

DASYLab is detailed in a separate document, *DASYLab* User's Manual, p/n 472-0901. You can obtain additional information from your sales representative or from the world wide web at:

<http://www.iotech.com>

DaqX, Language Drivers for Programmers

No programming knowledge is required for using WavePort in conjunction with the included *Out-of-the-Box* software package; However, a set of language drivers is included on the install CD-ROM for individuals who want to develop their own custom applications using:

- **C/C++**
- **Visual Basic**
- **Delphi**

The CD includes program examples and a Programmer's Manual (p/n 1008-0901) in PDF format.

The Programmer's Manual automatically installs during software installation for WaveBook Support, and will be located in the directory you chose to install the WaveBook Support programs.

Note that you will need to use Adobe® Acrobat Reader, version 3.0 or later, to view or print the manual. We have included a copy of the reader on the CD.

Software Setup Notice for WavePort... 6-1
Introduction..... 6-2
Software Startup & Sample Acquisition..... 6-2
Startup WaveView..... 6-2
Configure Channels..... 6-4
Configure Acquisition..... 6-5
Collect Data..... 6-6
Store Data [and View File Data], Option..... 6-7
WaveView Configuration Main Window..... 6-7
Menu Items & Buttons..... 6-7
File..... 6-8
Edit..... 6-8
View..... 6-8
System..... 6-9
Input Channel Configuration..... 6-10

Data Conversion..... 6-12
Acquisition Configuration..... 6-13
General Information 6-13
Trigger Types 6-14
External Clock and Counter-Timer 6-15
Digital Pattern Trigger..... 6-16
Pulse Trigger 6-17
WaveView Scope Window..... 6-18
Menu Items & Buttons..... 6-19
File..... 6-19
Acquire..... 6-19
Charts..... 6-19
Scope Display..... 6-20
WaveView Direct-To-Disk Window... 6-21

Software Setup Notice for WavePort

WavePort/PE16 makes use of two Dynamic Signal MODULES (**WBK14**); **WavePort/PE8** makes use of one such module. You must set pertinent software parameters from the *WaveView Configuration* main window. Related *Input Channel Configuration* information begins on page 6-10.

In WaveView, **WavePort/V8** appears as a WaveBook. The other two WavePort/V versions (V16 and V24) appear as a WaveBook and one (or two) WBK10A modules. **WavePort/V24** makes use of two Analog Expansion MODULES (**WBK10A**); **WavePort/V16** makes use of one such module. You must set pertinent software parameters from the *WaveView Configuration* main window. Related *Input Channel Configuration* information begins on page 6-10.

The *Module Configuration* window allows you to set the following *Excitation Source* parameters: **amplitude, offset, waveform, and frequency.**

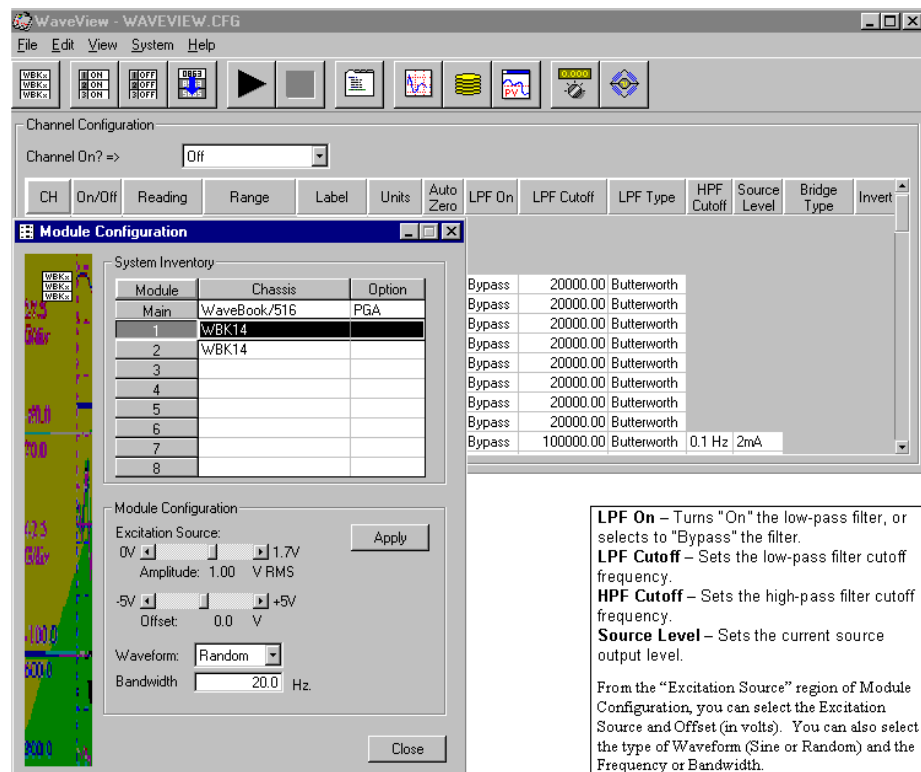

WaveView and Module Configuration Windows

WavePort/PE units appear as a WaveBook with one WBK14 (PE8), or two WBK14s (PE16).
 WavePort/V units will appear as a WaveBook with one WBK10A (V16), two WBK10As (V24), or none (V8).

Note: WBK14-related information does not apply to WavePort/V units.

Introduction

WaveView is a graphical Windows-based program for use in WaveBook applications. The program allows users to acquire data for immediate viewing or for storage to the PC's hard disk. No programming knowledge is required by the user.

From *WaveView* you can:

- Set up all analog or digital input parameters.
- Acquire and save data to disk.
- View the acquisition in real-time.
- Send data to other Windows applications, such as spreadsheets and databases.
- Launch an independent application (*DIAdem*) to view file data recorded by *WaveView*. Refer to Chapter 7, *DIAdem*, for detailed information.

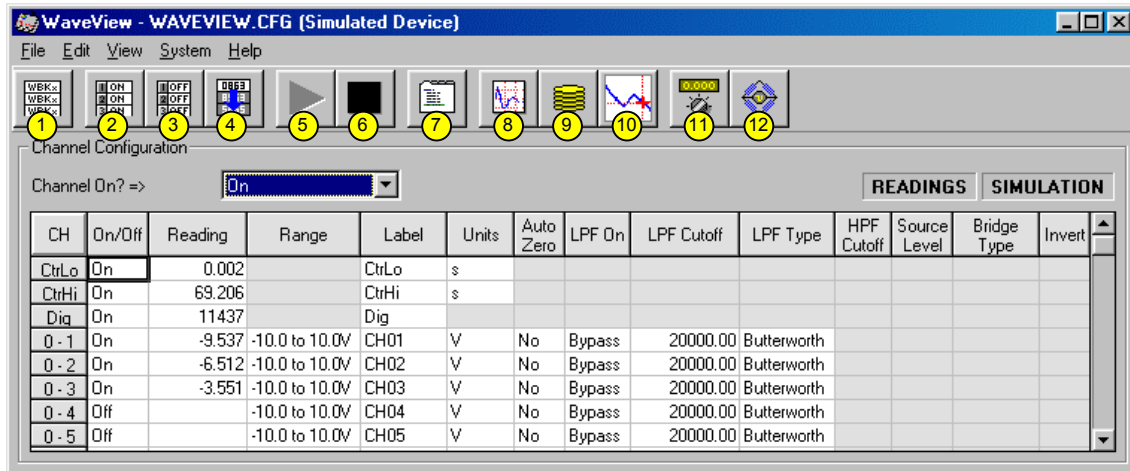

WaveView Configuration Main Window

Item	Description	Item	Description
1	Open Module Configuration Window	7	Open Acquisition Configuration Window
2	Make All Channels Active	8	Open WaveView Scope Window
3	Make All Channels Inactive	9	Open WaveView Direct to Disk Window
4	Fill Down (copy selected cell to lower ones)	10	View File Data (launches <i>DIAdem</i>)
5	Enable Spreadsheet Reading Column	11	Auto Zero Enabled Channels
6	Disable Spreadsheet Reading Column	12	Open WBK16 Sensor Calibration Window

Software Startup & Sample Acquisition

The program installation CD-ROM contains both a 16-bit and a 32-bit version of *WaveView*. The figures in this chapter reflect the 32-bit version, only. Note that the 16-bit version has fewer toolbar buttons and exhibits minor screen differences.

Startup WaveView

Start *WaveView* by double-clicking on its icon. *WaveView* holds user-configured parameters that can be saved to disk. The default configuration filename is **WAVEVIEW.CFG**. When *WaveView* starts up, it searches the working directory for this configuration file. One of the following 5 situations will occur:

- **If the default configuration file is found**, all the required setup information is extracted from it, and the application's main window opens.
- **If the default configuration file is not found**, *WaveView* attempts to connect with WaveBook using the following default parameters: Printer Port LPT1, Interrupt Level 7, and 4-bit Standard Protocol. If this fails, the program tries LPT2 and Interrupt Level 5.
- **If connection is established**, *WaveView*'s main window opens.

- **If the above fail**, a dialog box appears, providing you with certain options. These are: Retry, Select Device, Load File, and Exit. (See following figure).

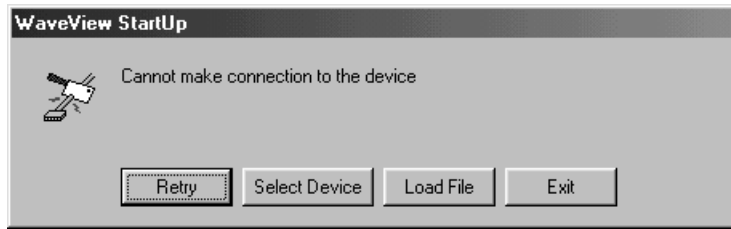

WaveView StartUp Box



Reference Note:

Refer to page 8-2 of the Troubleshooting Chapter for advice regarding connection problems.

- **If no user-configuration file is found, or if no communication established**, a dialog box prompts you to choose an actual WaveBook from the device inventory, or to select a *simulated device*.

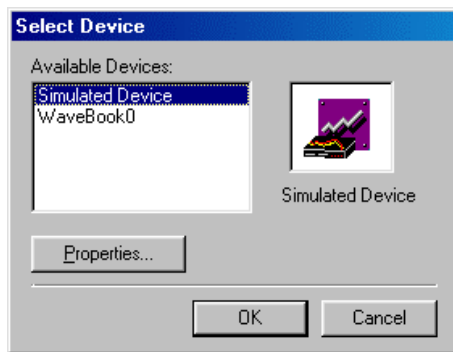

Select Device Box

Simulated WaveBook. If the hardware is not available, or if you just want to practice using the software, select *Simulated Device*. The *Simulated Device* allows you to run various software functions with no hardware concerns.

The *Simulated* mode is also available from *WaveView*'s pull-down menu. To select the simulated mode:

1. Choose *Select Device* from the *System* pull-down menu.
2. Select *Simulated Device* from the *Available Devices* list.

WaveBook Attached. If the WaveBook hardware is connected and switched on, select the applicable WaveBook device. Then click on the Properties button to view the *Device Properties* screen (see following figure).

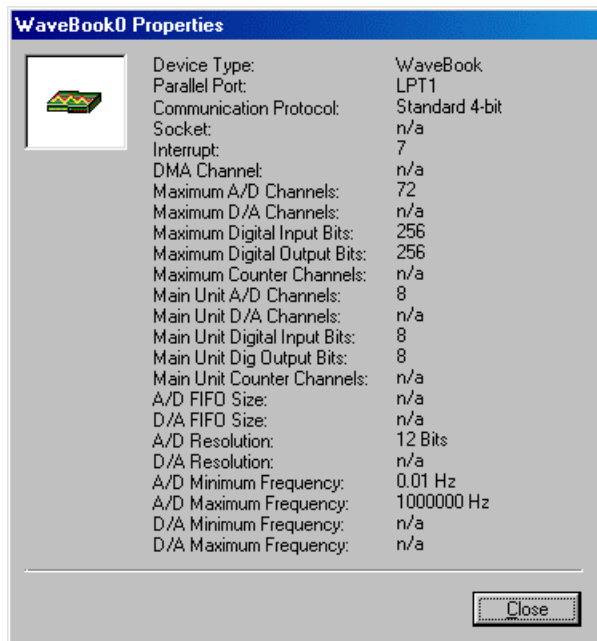

Devices Properties

After you have selected the device parameters, click *Close*.

WaveView attempts to find the WaveBook at the specified port. One of the following situations will occur:

- **The hardware is found**, the *WaveView* main window opens.
- **The hardware is not found**, a dialog box informs you and provides another chance to select parameters.



Tip If *WaveView* cannot identify the hardware, and you have verified that the selected hardware parameters are correct, exit *WaveView* and then use the “Test Hardware” feature of the Daq* Configuration control panel. A discussion of this feature begins on page 2-6.

WaveView interrogates the hardware after it starts up to see what options and expansion modules are actually connected to the WaveBook. The number of channels (shown on the configuration menu) represents the number of channels actually connected to WaveBook.

Configure Channels

Once *WaveView* determines the options and expansion modules, the individual channels can be configured, as described in the text that follows.

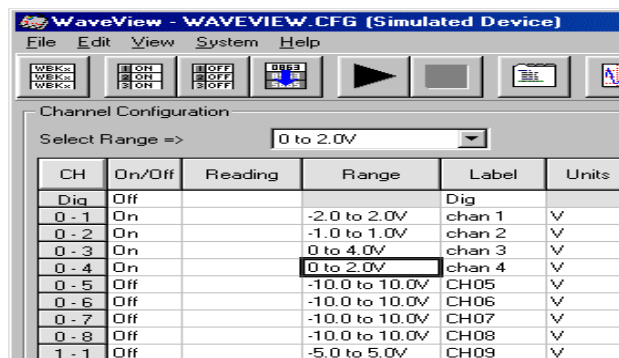

Configuring Channels from WaveView's Main Window

- **On/Off Column.** To acquire data with *WaveView*, channels must be properly connected to signal sources, and must be enabled (On). Channels can be enabled as follows:
 - (1) Click in a channel's *On/Off* cell, then select "On" from the drop-down menu (that appears above the range column), or

- (2) Double-click in a channel's *On/Off* cell to toggle to "On." Note that the on/off status will change with each double-click, or
- (3) Click on the toolbar's "On" button (Make All Channels Active) to turn all channels on. Note that the "Off" button (Make All Channels Inactive) turns all channels off.

- **Reading Column.** Not user configurable. This column displays values of enabled channels.
- **Range Column.** Select a channel's range in one of two ways.
 - (1) Click in a channel's *Range* cell, then select the desired range from the drop-down menu.
 - (2) Continue to double-click in the applicable channel's *Range* cell to cycle through the available ranges. Stop double-clicking when the desired range is indicated.
- **Label Column.** Channels have default labels, such as CH05. You can change the label by clicking on the cell, then typing in the new label. Labels must be unique, i.e., each channel must have its own label. Attempts to use duplicate labels, or use no label will result in a warning message.
- **Units Column.** Select a channel's units in one of two ways.
 - (1) Click in a channel's *Units* cell, then select the desired units from the pull-down menu.
 - (2) Double-click in a channel's *Units* cell to cycle through the units. Note that when the **mX+b** dialog box appears you need to click "OK" to continue cycling.

Note: You can use the **mX+b** equation to adjust a channel's scale and offset. You can enter user-defined units from the **mX+b** dialog box.



Configure Acquisition

The following text describes how to configure an acquisition.

After completing channel configuration, select the *Acquisition Configuration* option from the *View* menu or the tool bar. The following figure represents the *Acquisition Configuration* dialog box. The parameters shown are a result of the values entered below.

Scanning		Duration	Rate	Internal	External
Pre-Trigger	1000.	scans	50	kHz	
Post-Trigger	5000.	scans	50	kHz	
Convention	Scans		Frequency		

Triggering

Type: Manual

Acquisition Configuration Dialog Box

Triggering

Type: *Manual*

Scanning Duration

Convention: *Scans*

Pre-Trigger: 1000 scans

Post-Trigger: 5000 scans

Scanning Rate

Clock: *Internal*

Convention: *Frequency*

Pre-Trigger: 50 kHz

Post-Trigger: 50 kHz

After entering the values, click the Close button to set the acquisition parameters.



Collect Data

The following text describes how to collect data for a sample acquisition.

To read data from the WaveBook (or *Simulated Device*), select the *Scope* option from the *View* menu or the tool bar. The *WaveView Scope* window will display. Complete the acquisition setup as follows:

- **Number of Charts.** First, the *Scope* window should be configured to display 4 charts since 4 channels were previously selected for the acquisition. Select the *Number of Charts* option from the *Charts* menu item. When the flyout appears showing a selection of up to 8 channels for display, click on 4.
- **Arm and Trigger.** The system is now set to start collecting data. At this point, you may acquire one acquisition or continuous acquisitions. For this sample acquisition, click the *Arm* button, then click the *Trigger* button.
- **Data Acquisition.** The system has now collected 1000 pre-trigger scans and 5000 post-trigger scans.

If desired, you may modify the current *Scope* window display as follows:

- View additional channels (up to 8) simultaneously by changing the entry in the *Number of Charts* menu.
- Change the channels viewed. Use the channel select list box at the right of the waveforms to display waveforms of other active channels.
- To scale the waveforms, click on the *Scale All Charts* button. All 4 waveforms should then be visible.
- Examine the waveforms at any point along the timeline by using the horizontal scroll-bar.
- Vary the number of scans displayed by using the *Zoom In* or *Zoom Out* buttons.

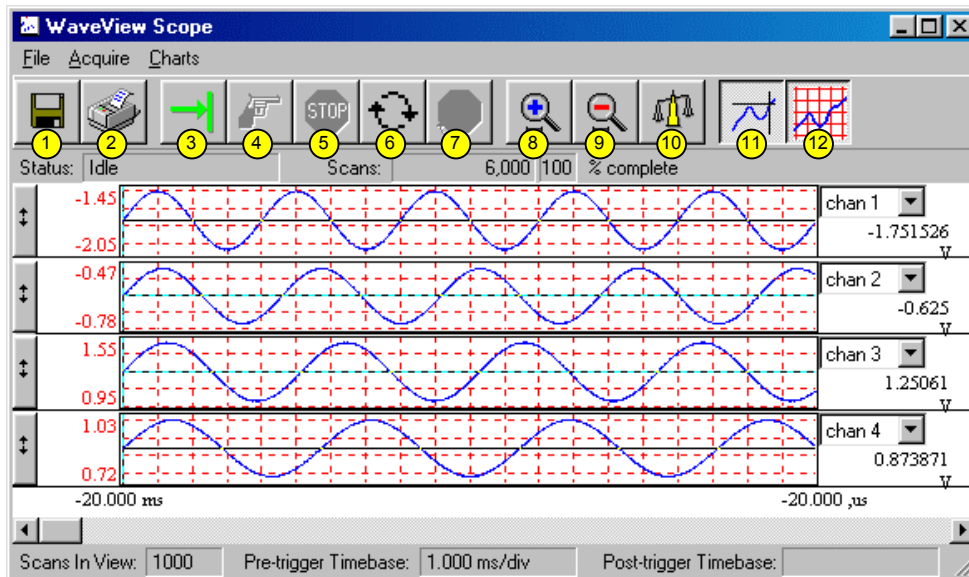

WaveView Scope Window

Item	Description	Item	Description
1	Save	7	Stop Rearming
2	Print Window	8	Zoom In
3	Arm	9	Zoom Out
4	Trigger	10	Scale All Charts
5	Stop Acquiring	11	Toggle Cross Hairs
6	Auto-Rearm	12	Toggle Grids

Store Data [and View File Data], Option



Data to be viewed with the post acquisition data viewer must be in the appropriate binary format. From *WaveView*, you can select the format by navigating as follows: *WaveView Main Window* ⇒ *File* ⇒ *Data Conversion Preferences* and check the appropriate box.

Save collected data to disk by clicking on the *Save* button ("floppy disk" or left-most button) of the *WaveView Scope* window, and then giving the file a name. Note that you can analyze the saved data with *DIAdem*, a post-acquisition data-viewer program.

To open *DIAdem*, return to the *WaveView Configuration* main window then click on the *View File Data* toolbar button (button 10 in the following figure).



Reference Note:
For detailed information regarding *DIAdem*, refer to Chapter 7.

WaveView Configuration Main Window

The following figure shows a sample of the *WaveView Configuration* main window.

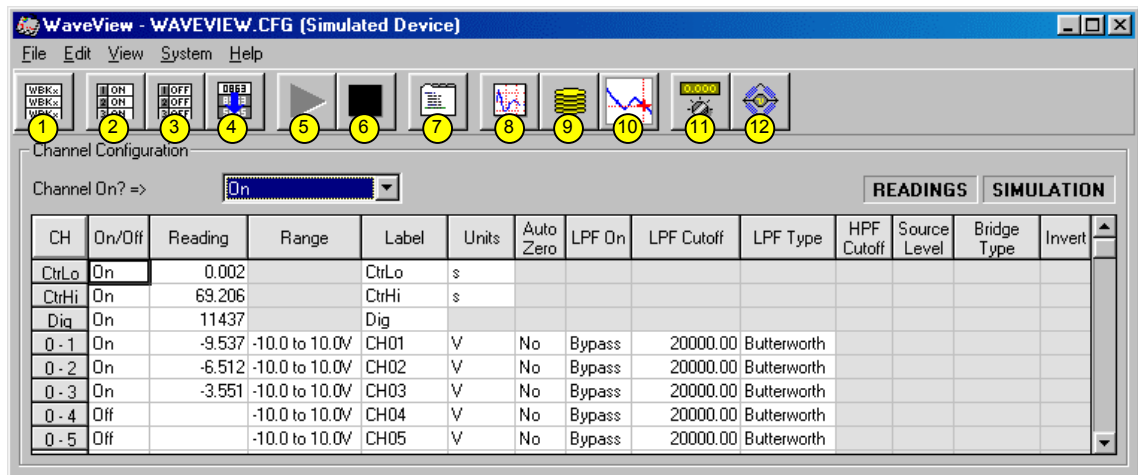

WaveView Configuration Main Window

Item	Description	Item	Description
1	Open Module Configuration Window	7	Open Acquisition Configuration Window
2	Make All Channels Active	8	Open WaveView Scope Window
3	Make All Channels Inactive	9	Open WaveView Direct to Disk Window
4	Fill Down (copy selected cell to lower ones)	10	View File Data by launching separate program
5	Enable Spreadsheet Reading Column	11	Auto Zero Enabled Channels
6	Disable Spreadsheet Reading Column	12	Open WBK16 Sensor Calibration Window

WaveView interrogates the hardware after it starts up to see what options and expansion modules are actually connected to the WaveBook. The number of channels displayed on the configuration menu corresponds to all the channels connected.

Menu Items & Buttons

WaveView functions are initiated through toolbar buttons and pull-down menu selections. The toolbar buttons are identified in the above figure. In the following sections, menu functions are explained in order of the menu structure.

Note: The following menu descriptions also apply to corresponding toolbar buttons, when applicable. Not all menu items have a corresponding tool button.

File

New	Sets all parameters to their default startup settings.
Open	Loads a saved configuration.
Save	Saves the existing configuration for later recall.
Save As	Prompts for a file name and saves the current configuration to that file name.
Convert Data Files	Runs the File Converter, which converts any acquired data file to any of the supported data types.
Data Conversion Preferences	Opens a dialog box, which lets you set the data file conversion options that WaveView will apply automatically whenever you acquire data.
Open a WBK16 Calibration File (WBK16 Only)	Loads a WBK16 sensor calibration table. This command loads saved WBK16 calibration data. Note: This selection is not available unless WaveView detects the presence of a WBK16.
Exit	Closes WaveView. Note: Before WaveView exits, it saves the current configuration in a file named WAVEVIEW.CFG. The next time you run WaveView, this file is loaded automatically.

Edit

Make All Channels Active	This command places an "On" in the "On/Off" field of all channels.
Make All Channels Inactive	This command places an "Off" in the "On/Off" field of all channels. If your channel scan includes only a few channels, it may be easier to make all of the channels inactive, then turn on only those few channels that you want.
Go To Row	Opens a dialog box that lets you enter a channel number to be modified. For hardware configurations that contain a large number of channels, this is a faster method of moving around than using the scroll bars.
Fill Down	When multiple cells within a column are selected, this command takes the top-most selected cell and copies its contents to the selected cells below.
Hide Inactive Channels	Temporarily removes all inactive channels from the channel configuration worksheet. If there are inactive ("Off") channels, this results in a smaller spreadsheet showing just the currently active channels. A status indicator "HIDDEN ROWS" appears above the spreadsheet when one or more channels are hidden. Note: When a channel is hidden, its configuration settings cannot be changed. Block operations and other "All" actions, like the Make All Channels Active menu item, have no effect on hidden channels.
Show All Channels	Makes all channel rows visible. Can be used to restore the full spreadsheet after a Hide Inactive Channels action.
Auto Zero Enabled Channels	This zeros out a DC offset signal on all channels that are "On" and have Auto Zero set to "Yes."
Enable Spreadsheet Reading Column	This causes all channels that are "On" to display an actual reading of the input signal in the channel reading column. This column is updated with new readings about twice per second. A status indicator "READINGS" appears above the spreadsheet when the reading column is enabled.
Disable Spreadsheet Reading Column	This stops the reading column from being updated.

View

Acquisition Configuration	Opens the display window to allow selection of the number/speed of the scan and the triggering method to start the scan.
Module Configuration	Opens the display window that shows the current inventory of expansion modules in the system and allows the configuration of some expansion module parameters.
Scope	Opens the display window to allow real-time viewing of the acquired data.
Direct to Disk	Opens the display window to allow the writing of acquisition data to disk files.
View File Data	Starts the independent application to view file data.

System

Select Device	Brings up a dialog box that lets you select a WaveBook device. It also provides access to the Simulated Device, which is listed as an option.
Options	Brings up the WaveView System Options dialog box. From there, you can enable or disable WaveView options. The Performance and Memory Module options are described below.
WBK16 Sensor Calibration (WBK16 Only)	This command runs the sensor calibration program. Selecting this option will temporarily disable WaveView and open a sensor calibration spreadsheet so that each channel on a WBK16 can be calibrated to the specifications of the sensor in use. Note: This selection is available if WaveView detects a WBK16 module.
WBK16 Advanced Features (WBK16 Only)	This command brings up a dialog box to select new cutoff frequencies for the LPF on a WBK16. The WBK16 has a Low Pass Filter with two selectable cutoff frequencies. Although the frequencies are factory configured at 10 Hz and 1 kHz, changing the resistor packs inside the WBK16 can modify them. After the cutoff frequencies are altered, the values that WaveView displays can then be modified to match the LPF frequencies using this command. Note: This selection is available if WaveView detects a WBK16 module.

Performance

- **Acquisition Data Packing:**
The Data Packing option does not apply to WavePort and is disabled.

- **Calibration:**



WavePort should only be calibrated at the factory, or by a factory-authorized service representative.

Leave the Calibration Radio Button selected to *Factory Calibration Table* (see figure at right). The *Calibration* section of Chapter 9, *Maintenance, Service, and Part Replacement*, contains additional information.

- **Acquisition Buffer Size:**
Allows you to set a new buffer size for data acquisition. The dialog displays the maximum size of the acquisition buffer. The buffer is never sized larger than needed by the acquisition. For a one-channel, 1000 scan acquisition the buffer will be 2000 bytes, *not* the size shown in the dialog.

Memory Module

Note: The WaveView System Memory Module Option settings are only pertinent if a WBK30 Memory module option card is installed in your WavePort or WaveBook.

- **Pre-Trigger Mode:** This allows you to use the full bandwidth of your instrument regardless of the computer's data transfer speed. Note that when Pre-Trigger is in effect, certain conditions apply: (1) The entire acquisition must fit in the WBK30's internal memory, (2) The scan count will not update during acquisition, and (3) The Pre-Trigger Mode selection only applies if pre-trigger is used.
- **Overflow Protection:** This preserves and transfers all data in the instrument when an acquisition ends early due to an error or manual disarm. This option should not be used if you: (1) Never want to save data from an incomplete acquisition, or (2) You want the option to work like it does without a WBK30 installed.

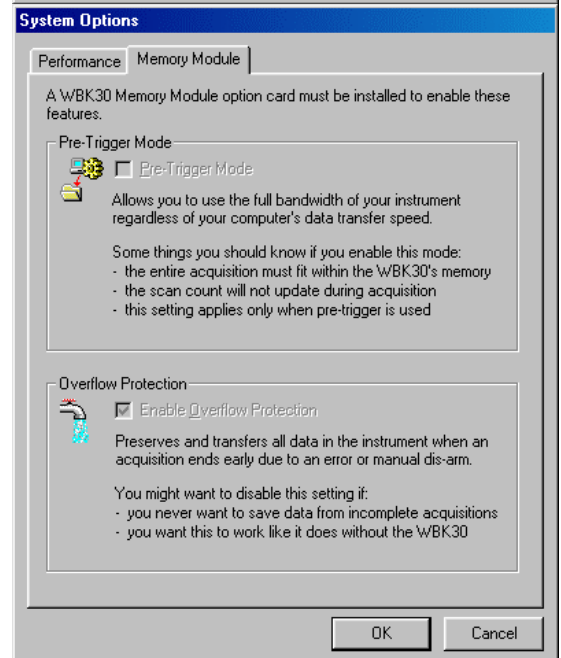
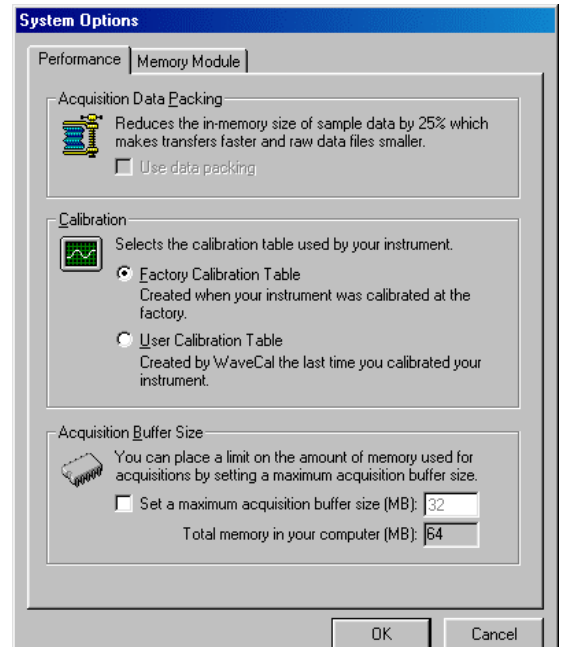

Input Channel Configuration

CH	On/Off	Reading	Range	Label	Units	Auto Zero	LPF On	LPF Cutoff	LPF Type	HPF Cutoff	Source Level	Bridge Type	Invert
CtrlLo	On			CtrlLo	s								
CtrlHi	On			CtrlHi	s								
Dig	On	23235		Dig									
0-1	On	2.027	-10.0 to 10.0V	CH01	V	Yes	On	20000.00	Butterworth				
0-2	On	4.012	-10.0 to 10.0V	CH02	V	Yes	On	20000.00	Butterworth				
0-3	On	6.022	-10.0 to 10.0V	CH03	V	Yes	On	20000.00	Butterworth				
0-4	On	0.017	-10.0 to 10.0V	CH04	V	Yes	On	20000.00	Butterworth				
0-5	On	2.016	-10.0 to 10.0V	CH05	V	Yes	On	20000.00	Butterworth				
0-6	On	4.019	-10.0 to 10.0V	CH06	V	Yes	On	20000.00	Butterworth				
0-7	On	6.011	-10.0 to 10.0V	CH07	V	Yes	On	20000.00	Butterworth				
0-8	On	0.040	-10.0 to 10.0V	CH08	V	Yes	On	20000.00	Butterworth				
1-1	On	1.020	-5.0 to 5.0V	CH09	V	Yes	On	100000.00	Butterworth	0.1 Hz	Off		
1-2	On	2.005	-5.0 to 5.0V	CH10	V	Yes	On	100000.00	Butterworth	0.1 Hz	Off		
1-3	On	3.015	-5.0 to 5.0V	CH11	V	Yes	On	100000.00	Butterworth	0.1 Hz	Off		
1-4	On	0.009	-5.0 to 5.0V	CH12	V	Yes	On	100000.00	Butterworth	0.1 Hz	Off		
1-5	On	1.018	-5.0 to 5.0V	CH13	V	Yes	On	100000.00	Butterworth	0.1 Hz	Off		
1-6	On	2.014	-5.0 to 5.0V	CH14	V	Yes	On	100000.00	Butterworth	0.1 Hz	Off		

Channel Configuration Spreadsheet

The spreadsheet allows the analog input channels and/or digital channel to be configured and displayed. The spreadsheet consists of rows and columns much like an accounting spreadsheet. The top few rows are used for the high-speed digital input and other non-analog channels. The following rows (up to 72) configure the analog input channels. The number of rows varies depending on system configuration.

The various columns contain the configuration information for each channel. Some columns allow blocks of cells to be altered simultaneously, while others allow one cell to be changed at a time. Some columns may be static and cannot be altered. Clicking a column header will select the entire column if applicable.

- **CH.** The channel number column labeled CH is static and cannot be altered. This column identifies the analog (or digital) input channel to be configured in that row. This number includes all channel numbers from the WaveBook and any attached expansion chassis (WBK10/10H/10A, WBK14, WBK15, and WBK16). The channels are numbered as follows:

CH	Description	Default Label
CtrlLo	WavePort External Clock Period (Lo)	CtrlLo
CtrlHi	WavePort External Clock Period (Hi)	CtrlHi
Dig	WaveBook Digital Channel	Dig
0-1 to 0-8	WaveBook Analog Channels	CH01 to CH08
1-1 to 1-8	First set of Expansion Channels*	CH09 to CH16
2-1 to 2-8	Second set of Expansion Channels*	CH17 to CH24
*WavePort/PE units appear as a WaveBook with one WBK14 (PE8), or two WBK14s (PE16).		
*WavePort/V units will appear as a WaveBook with one WBK10A (V16), two WBK10As (V24), or none (V8).		

- **On/Off.** This column allows you to include or exclude a channel from the scan list. When a cell is selected, the selection box above the spreadsheet allows “On” or “Off” to enable or disable the channel. Double-clicking a cell in this column will toggle the channel status. The *Make All Channels Active* and *Make All Channels Inactive* menu items under the *Edit* menu can be used to globally change all channels to either “On” or “Off.”
- **Reading.** Not user configurable. This column displays values of enabled channels.
- **Range.** This column allows you to set the gain and polarity for the selected channel(s). Clicking the mouse in any of the analog channel *Range* boxes brings up the "Select Range" selection box. The range of gains available in the selection box depends on the hardware installed in the system. Double-clicking on a channel's *Range* box will cycle through the available ranges. The *Range* selections have no effect on the Digital Input channel.



Reference Note:

Ranges are presented in Chapter 10, *Specifications*.

- **Label.** This column contains a descriptive name for the input channel. By default, it contains a label that is similar to its channel number, but this can be changed to any combination of 8 characters. Click on the desired cell, and type in the desired label name. This column does not have a selection list above the spreadsheet and does not allow selecting multiple blocks of cells.
- **Units.** This column allows you to change the voltage scale setting of each analog channel displayed when the Scope option is selected. When a cell is selected, a selection box gives you a choice between volts (V) or millivolts (mV). You can also enter user units and $mX+b$ scales from this point. Making a selection sets the choice into the individual cell or block of cells. This option has no effect on the Digital Input channel.

From the $mX+b$ dialog box, you can enter values for m and b components of the equation that will be applied to the data. There is also an entry field that allows you to enter a label for the new units that may result from the $mX+b$ calculation.

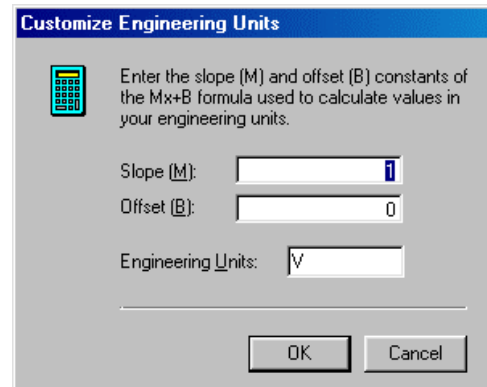

- **Auto Zero (32-Bit WaveView Only).** Auto-zero is used to null out any DC offset that might be present in a channel. WaveView nulls out the offsets of all channels set to “Yes” in the Auto Zero column, providing the channels are enabled (“On”).

The following options depend on your actual WaveBook configuration.

- **LPF On (WBK12/13, WBK14, WBK16).** This column allows you to include or exclude the low-pass filter from a channel. When selecting a cell, the selection box above the spreadsheet allows “On” or “Bypass” to enable or disable the filter or block of filters. In WBK14 applications, LPF On allows you to select an external filter. Double-clicking a cell in the LPF On column will cycle through the available options.
- **LPF Cutoff (WBK12/13, WBK14, WBK16).** This column allows you to set the low-pass filter cut-off frequency for the selected channel(s). If you enter an inappropriate cut-off frequency, the software will round up or down to the next appropriate frequency for your particular hardware. Since the WBK12/13 filters are assigned to banks, setting one channel of a bank will also update the others.
- **LPF Type (WBK12/13, WBK14, WBK16).** This column allows you to configure the low-pass filter for the selected channel(s). When selecting a cell or block of cells in this column, a selection box above the spreadsheet may or may not appear, depending upon your particular hardware. If the selection box appears, it will display the appropriate low-pass filter selections (such as “Elliptic” or “Linear” for the WBK12/13) allowed by your hardware. Double-clicking a cell in this column will toggle the filter-type status. A change in the low-pass filter type for one channel will appropriately update any other affected channels.
- **HPF Cutoff (WBK14, WBK16).** This column allows you to set the high-pass filter cut-off frequency for the selected channel(s). When a cell is selected, a selection box above the spreadsheet will display the appropriate cut-off frequency selections (such as “0.1 Hz” or “10 Hz” for a WBK14 or “DC” and “10 Hz” for a WBK16) to configure the filter(s). Double-clicking a cell in this column will toggle the cut-off frequency status. A change in the high-pass filter cut-off frequency for one channel will appropriately update any other affected channels.

- **Source Level (WBK14, WBK16).** This column allows you to apply or remove the source level for the selected channel(s). When selecting a cell or block of cells in this column, a selection box above the spreadsheet may or may not appear, depending upon your particular hardware. If the selection box appears, it will display the appropriate source level selections (such as “Off”, “2 mA”, or “4 mA” for a WBK14 or an excitation voltage level for a WBK16) allowed by your hardware to configure a source or block of sources. Double-clicking a cell in this column will toggle the source level status. A change in the source level for one channel will appropriately update any other affected channels.

Note: For WBK14 Only, when using an ICP transducer, either 2 mA or 4 mA must be selected. Set the current-source level to “Off” before measuring voltage.

- **Bridge Type (WBK16 Only).** This column allows you to select the specific bridge configuration for a strain gage or load cell sensor. When a cell is selected, a selection box above the spreadsheet will display the appropriate bridge configuration selections (such as *Full Bridge*, *Half-Bridge* and *Quarter-Bridge*). Double-clicking a cell in this column toggles the Bridge Type.
- **Invert (WBK16 Only).** This column allows you to invert the signal level of a channel. When a cell is selected, the selection box above the spreadsheet allows “Yes” or “No” options to determine whether the channel is inverted. Double-clicking a cell in this column will toggle the invert status.

Data Conversion

WaveView contains a file converter capable of converting raw binary data to other file formats. From the *File* pull-down menu, select *Data Conversion Preferences* to choose the desired file formats. Note that the application for viewing file data is selected by default. The following window is displayed:

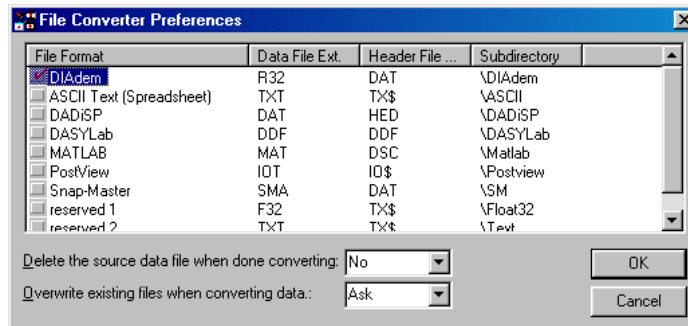

Check any box to set the file conversion options that WaveView will apply automatically to acquired data.

WaveView’s *Convert Data Files* option of the *File* menu allows you to run the File Converter on previously acquired data. A dialog box is displayed for you to select files from:

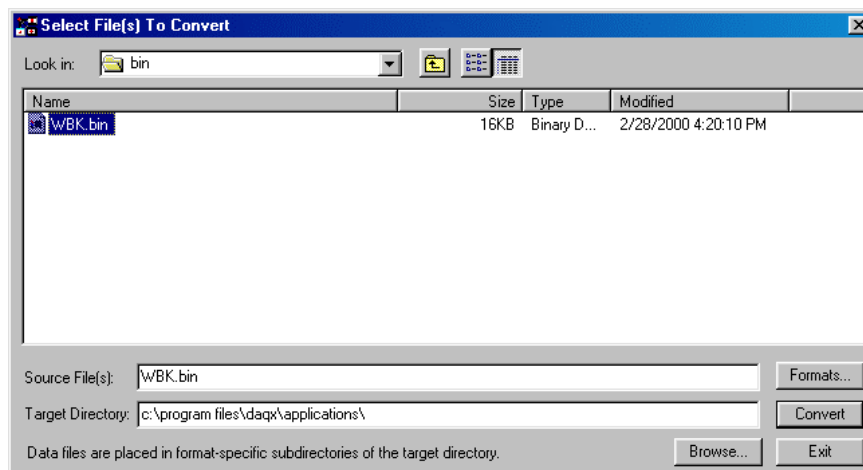

During the conversion, a “Converting File” box shows an animated completion bar, the format of the source and target files, and the file paths of the source and target.



Acquisition Configuration

General Information

You can access the *Acquisition Configuration* dialog box from the main window's *View* pull-down menu or toolbar.

The **Duration** column has text-boxes for pre-trigger scans, post-trigger scans, and convention (number of scans or time period).

The following formula determines the maximum number of scans that can be stored for use in the Scope mode.

This does not apply to storage to disk.

$$(\text{Scan duration}) * (\# \text{ of Channels}) * 4 < \text{Available PC Memory}$$

A scan includes all channels that are set to "On" in the analog input configuration spreadsheet.

The **Rate** column allows you to set pre-trigger and post-trigger scan rates. Timebase settings can be for *Frequency* or *Period*. Timebase units are as follows:

Frequency - Hz, kHz, or MHz.

Period - seconds, milliseconds, or microseconds.

The scan rate can also be driven by the **External** clock of the digital input port. With this option, enabled scans occur as pulses are input on the external clock pin. The scan rate is set as a fraction of the external clock rate by the **Clock Divider** setting. The fastest scan rate is obtained from a clock divider setting of 1. A setting of 10 would take one scan every tenth pulse.

Scanning		Rate	Internal	External	Close
Pre-Trigger	1000 scans	50	kHz		
Post-Trigger	5000 scans	50	kHz		
Convention	Scans	Frequency			
Triggering					
Type:	Manual				

Acquisition Configuration (Internal Clock)

Scanning		Rate	Internal	External	Close
Pre-Trigger	0 scans	Clock Divider (1-255):		88	
Post-Trigger	4000 scans				
Convention	Scans				
Triggering					
Type:	Immediate				

Acquisition Configuration (External Clock)

Trigger Types

The *Trigger* selection pull-down list allows you to select the triggering method to start the scan. The figure shows the various triggering options available.

Immediate

Triggering starts immediately when the *Arm* toolbar button of *WaveView Scope* is clicked.

Manual

Prior to acquiring data, the system must first be armed by clicking on the *Arm* toolbar button of *WaveView Scope*. Triggering starts when the *Trigger* button is clicked.

Digital

Selecting *Digital* brings 2 triggering options to the *Trigger* selection box, allowing you to select either a "Rising" or "Falling" edge trigger. The TTL trigger signal connects to pin (TTLTRG) of the Digital I/O & Trigger port on the WaveBook front panel.

Channel 1 Analog

This option allows you to set up additional parameters for the acquisition of analog data. Several new items are added to the *Trigger* selection box, including options for the *Trigger Condition* and *Trigger Threshold*.

The selections for trigger correspond to the following trigger conditions: (1) "Rising Edge", where the signal level must have a positive slope as it crosses the *trigger threshold*, or (2) "Falling Edge", where the signal level must have a negative slope as it crosses the *trigger threshold*.

Multiple Ch Analog

This Trigger Source provides a scroll list of Trigger Conditions for use with AND, or OR Logical Operators, as follows:

- (1) Selecting "OR channels" causes the acquisition to trigger when any of the selected channel conditions become true
- (2) Selecting "AND channels" issues a trigger when all the selected channel conditions become true.

If *Multiple Ch Analog* is selected, the *Trigger Condition* option has the following choices:

- ◇ **No Trigger.** The channel will not be included in the list of channels to examine for trigger conditions.
- ◇ **Rising Edge.** The signal level must first go below the trigger level by the user-set hysteresis amount. Then, the trigger channel is valid whenever the signal level is above the trigger level and stays valid until the signal level goes below the trigger level by at least the hysteresis amount.
- ◇ **Falling Edge.** The signal level must first go below the trigger level by the user-set hysteresis amount. Then, the trigger channel is valid whenever the signal level is below the trigger level and stays valid until the signal level goes above the trigger level by at least the hysteresis amount.

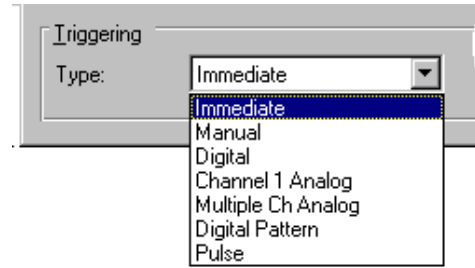

Trigger Source Pull-Down List
(On Acquisition Configuration Dialog Box)
Provides the means of selecting the desired Trigger Type.



Digital Trigger
With Digital Trigger, the user must indicate Rising or Falling Edge.

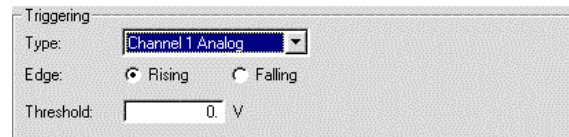

Channel 1 Analog Trigger
Allows you to set a Trigger Threshold Value and indicate whether the signal is to be Rising or Falling in relation to the trigger line.

Note: *Channel 1 Analog* triggering is only valid for channel 1.

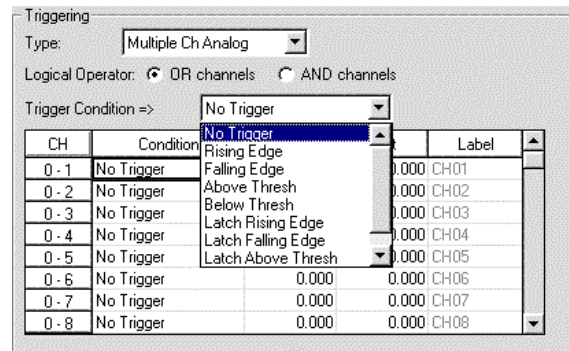

Multiple Ch Analog
Provides a variety of Trigger Conditions and the use of **And** or **Or** Logic Operators.

- ◇ **Above Thresh.** A trigger channel is valid whenever the signal level is above the trigger level and stays valid until the signal level goes below the trigger level by at least the user-set hysteresis amount.
- ◇ **Below Thresh.** A trigger channel is valid whenever the signal level is below the trigger level and stays valid until the signal level goes above the trigger level by at least the user-set hysteresis amount.
- ◇ **Latch Rising Edge.** The signal level must first go below the trigger level by the user-set hysteresis amount. Then, the trigger channel is valid whenever the signal level is above the trigger level and stays valid until the acquisition is complete.
- ◇ **Latch Falling Edge.** The signal level must first go below the trigger level by the user-set hysteresis amount. Then, the trigger channel is valid whenever the signal level is below the trigger level and stays valid until the acquisition is complete.
- ◇ **Latch Above Thresh.** A trigger channel is valid whenever the signal level is above the trigger level and stays valid until the acquisition is complete.
- ◇ **Latch Below Thresh.** A trigger channel is valid whenever the signal level is below the trigger level and stays valid until the acquisition is complete.

Note: The threshold voltage and hysteresis level may be set for each channel as required. Position the cursor per channel and enter the desired value(s).

External Clock and Counter-Timer

WavePorts can receive an **external clock** input through pin 20 of the DB25 connector labeled DIGITAL I/O, EXTERNAL CLOCK, TTL TRIGGER. This enables data scanning to be correlated with an **external pulse train**. To enable the **external clock**, select “External” for the Scanning Rate in the *Acquisition Configuration Dialog Box* (see following screen shot). When the external clock is enabled, WavePort **begins a scan only after a rising edge on the TTL level occurs**. Optionally, the external clock may be divided [by a factor of 1 to 255]. This “pre-scaling” allows the user to select a reduced scan rate.

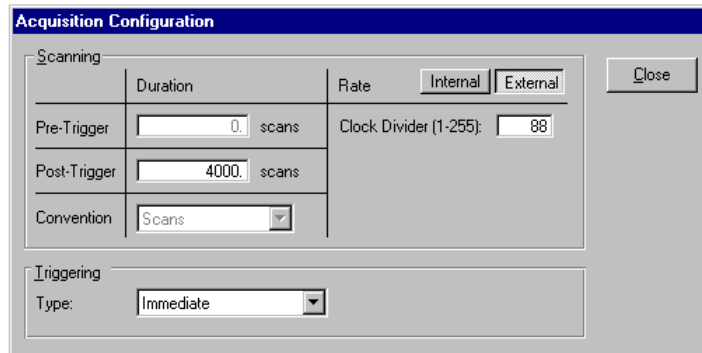

Acquisition Configuration Dialog Box with External Clock Enabled

Note: Clock Divider can be set from 1 to 255

WavePort has a 32-bit **internal counter** that calculates and reports the external clock’s period. The counter can be read with each scan of the analog data. This is often beneficial in later analysis, when there is a need to correlate physical phenomena with speed.

The counter channel actually consists of two independent channels (CtrLo and CtrHi). These can be turned “On” in the *Channel Configuration Spreadsheet*. When enabled, the low (CtrLo), then high (CtrHi) words of the counter will be configured in each scan. Note that the spreadsheet’s **Units** column can be used to view a predefined period in units of seconds, ms, or usec.

WaveView can be configured to read **only the low word** of the counter data (CtrLo: “On,” CtrHi: “Off”). This decreases the minimum scan period by 1 usec. This *LoCtr only option* can be used **only** when the external clock frequency is greater than 305 Hz (20,000,000 MHz / 65536). Note that WaveView does not enforce this.

Digital-Pattern Trigger

In addition to digital trigger, the WavePort series supports a digital-pattern trigger (not available in the WaveBook/512). This expanded capability allows data collection to start when a user-defined 16-bit digital pattern is matched on the digital I/O connector. This feature is useful when trying to capture noise, vibrations or some other physical disturbance that occurs at a particular point in a digitally-sequenced process (from a PLC or relay-logic-control system).

When “Digital Pattern” is selected as the Triggering *Type*, the 16-bit pattern extension appears (as indicated in the following figure). The *Condition* box allows the following choices:

Equal To (=) / Not Equal To (<>) – These options treat each digital line as a separate input to be compared to logical 1 or 0. Selecting “Equal To” triggers only on the exact pattern of 1’s and 0’s selected., while “Not Equal” triggers on all others. You can also set any of the inputs to “don’t care” (X), which excludes it from the comparison.

Greater Than (>) / Less Than (<) – These options interpret the digital inputs as a single 16-bit value and allow a threshold trigger.

The screenshot shows the "Acquisition Configuration" dialog box. It is divided into two main sections: "Scanning" and "Triggering".

Scanning Section:

- Buttons: "Internal" (selected), "External", "Close".
- Pre-Trigger: Duration: 0. scans; Rate: 10. kHz.
- Post-Trigger: Duration: 4000. scans; Rate: 10. kHz.
- Convention: Scans (dropdown); Frequency (dropdown).

Triggering Section:

- Type: Digital Pattern (dropdown).
- Condition: Equal To (=) (dropdown).
- Pattern: A 16-bit pattern field with bits 15 down to 0. All bits are currently set to 0.
- Buttons: "All 0's", "All 1's", "All X's (Don't cares)".

Acquisition Configuration Dialog Box, with Digital Pattern Extensions

Note: The top row contains a button labeled “External” for enabling the External Clock.

Pulse Trigger

Pulse Trigger allows the use of a high-bandwidth input for triggering, and the correlation of lower-speed waveforms with the occurrence of a high-speed pulse. You can set a pulse amplitude between ± 5 V and a pulse width in the range of 10 ns to 10 μ s.

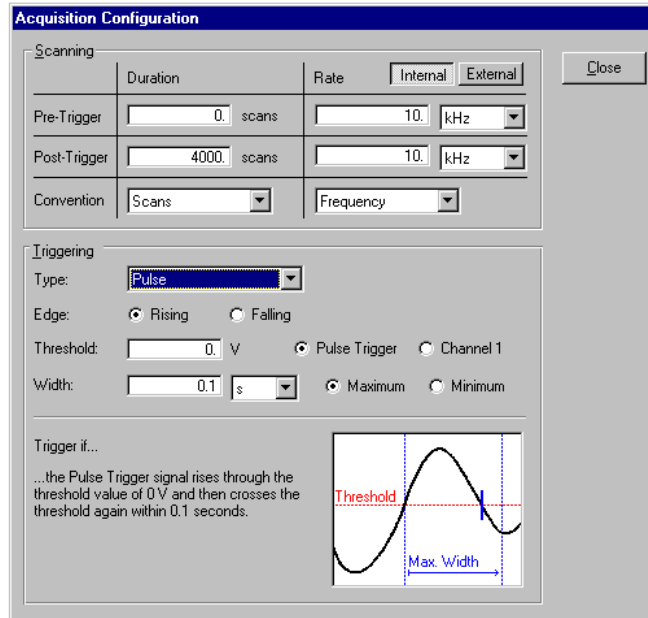

Pulse Trigger Selected

This option allows you to trigger on analog level “pulses” on either the Channel 1 input or the Pulse Trigger input. This trigger type is similar to the Channel 1 Analog trigger but places an additional time-based condition on the signal. Depending on whether the pulse width is set as a minimum or a maximum, the signal either must or must not cross the threshold again within the given amount of time.

The red horizontal line (Threshold) and blue vertical lines (defining maximum width) will vary according to the parameter settings. You can specify either one or two thresholds for the level and width settings. The number of labels matches the number of thresholds and the placement follows the polarity.

- For positive polarity, the text is “Rise Above... Stay Below.”
- For negative polarity, the text is “Fall Below and Stay Above.”

Note: When used as a maximum, the pulse width setting can capture signal pulses. As a minimum, it is useful for ignoring pulses.



WaveView Scope Window

Scope mode is a WaveView utility that can display data acquisition waveforms in real-time. Before this mode can be enabled, at least one channel must be "ON." Up to eight channels can be displayed at a time.

Note: The following formula determines the maximum number of scans that can be stored for use in the *Scope mode*. The formula does not apply to disk storage.

$$(\text{Total Scans}) * (\# \text{ of Channels}) * 4 < \text{Acquisition Buffer Size}$$

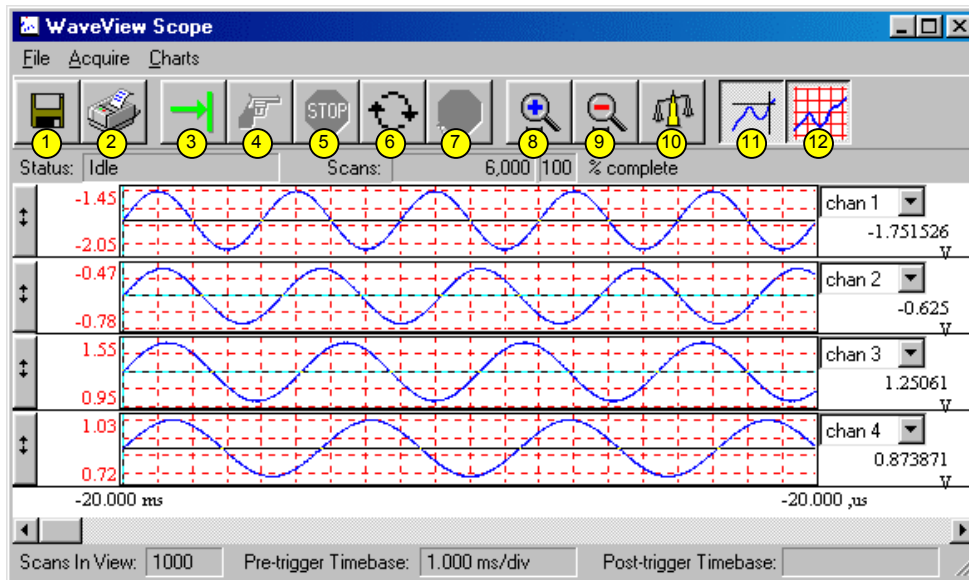

WaveView Scope Window

Item	Description	Item	Description
1	Save	7	Stop Rearming
2	Print Window	8	Zoom In
3	Arm	9	Zoom Out
4	Trigger	10	Scale All Charts
5	Stop Acquiring	11	Toggle Cross Hairs
6	Auto-Rearm	12	Toggle Grids



To view additional channels in Scope Display, simply change the entry in the *Number of Charts* selection of the Charts pull-down menu. You can simultaneously view up to eight channels in Scope Display.

A *Channel* pull-down menu box is located at the right end of each chart and is used to select the desired channel. Click on the box to display the channel list; then click on the desired channel.

The waveform display is actually a window looking at a section of the acquisition. The window size may be increased or decreased and moved to any location on the time-line. The waveforms may be examined during or after the acquisition.

Menu Items & Toolbar Buttons

You can control the acquisition process and the Scope display from the menu selections and toolbar buttons. There are more pull-down menu selections available than there are buttons; however, each button does have a corresponding menu item.

File

Save Data Files	Saves data in the file name and data formats that have been previously assigned.
Save Data File As	Prompts you for a name for the data file before saving the data.
Print Window	Prints the contents of the display screen.
Close Scope	Closes the Scope display and returns to the configuration menu.

Acquire

Arm	Arms the WaveBook to acquire data. Data acquisition will commence as soon as the triggering conditions are satisfied.
Trigger	Issues a Software Trigger to the WaveBook. Whenever the WaveBook is armed and waiting for a trigger, you can take this action to force data acquisition to start.
Stop Acquiring	Ends the current acquisition immediately. All data collected prior to this action will be retained in memory and displayed in the chart control. If auto-rearm is enabled, this action stops the rearming as well.
Auto-Rearm	When enabled, the WaveBook is automatically re-armed whenever an acquisition ends. With this feature, you can use WaveView like an oscilloscope to display a rapid series of your channel inputs.
Stop Rearming	With auto-rearm enabled, this action stops auto-rearming but allows the current acquisition to complete. (Pressing "Stop Acquiring" ends the current acquisition immediately.)

Charts

Number of Charts	Sets the number of charts (maximum of 8) to be displayed simultaneously.
Zoom In	Halves the visible timebase. Example: if 10 ms of information is visible, clicking Zoom In will show 5 ms. Maximum Zoom In is 2 samples.
Zoom Out	Doubles the visible timebase. Example: if 10 seconds of information is visible, clicking Zoom Out will show 20 seconds. Maximum Zoom Out is 2000 samples.
Enable AutoScaling	Continuously adjusts the Y-axis for all channels so that the visible waveform fills 90% of the graph's range.
Scale All Charts	Adjusts the Y axis for all channels so that the visible waveform fills 90% of the graph's range.
Display Cross Hairs	A cross hair is a marker that shows the numerical values of time and amplitude at its present location in the waveform. Toggle button to turn cross hairs on or off.
Display Grids	Displays a grid for each chart. Toggle button to turn grids on or off.

Individual cross-hairs can be moved by holding down the left mouse button and dragging the selected cross-hair to the new location on the chart. Holding the right mouse button and dragging, moves all the cross-hairs simultaneously to a new location. The voltage and time display at the side changes as you do this. Cross-hairs are disabled during an acquisition.

Scope Display

The following figure identifies features of the WaveView Scope display.

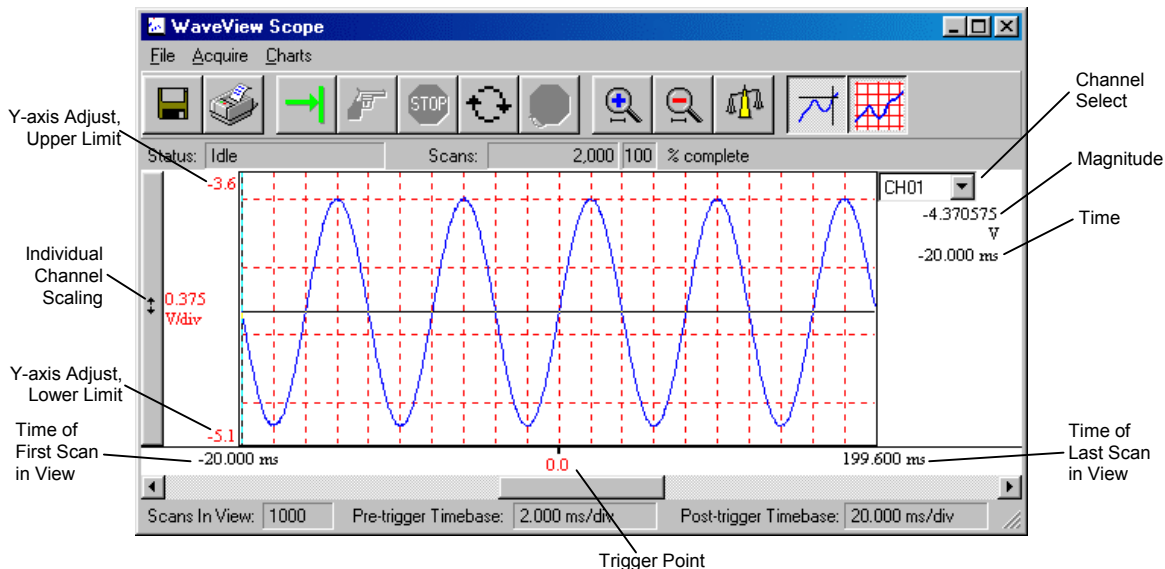

Scope Mode Indicators & Descriptions	
Y-axis Adjust	Allows adjustment of the displayed range. Clicking on the value highlights the number. Enter desired new value and press Enter.
Individual Channel Scaling	Adjusts the scaling of the individual channels so that the visible waveform fills 90% of the graphs range.
Time of First Scan in View	Displays the acquisition time of the first scan currently displayed on the chart.
Trigger Point	Displays the trigger event. Note: Depending on the current acquisition parameters and chart display configuration, the trigger point may or may not appear on the chart.
Time of Last Scan in View	Displays the acquisition time of the last scan currently displayed on the chart.
Channel Select	Clicking on this control displays the list of all channels selected in the WaveView configuration menu. A maximum of 8 channels may be displayed at one time with the remaining channels available through the scroll bar.
Magnitude	Displays the magnitude of the signal at the point where the marker cross-hair intersects the waveform. Moving the marker to different locations on the waveform changes the value of the displayed voltage.
Time	Displays the point on the acquisition time-line where the marker cross-hair intersects the waveform. This value changes as the marker is moved along the X-axis (time scale).

In addition to the above features of the Scope window, there are status bars above and below the charts that display information about the timebase of the current display and the status of the current acquisition:

Status – Indicates the current acquisition state of the WaveBook. If there is no acquisition in progress, the status is Idle. During an acquisition, the status steps through all or part of the following sequence: Configuring, Waiting For Trigger, Triggered, Transferring, Graphing, and then back to Idle.

Scans – During an acquisition, this field displays the current transfer count. Afterwards, it is the total scans in the previous acquisition. A percent complete value is shown to the right of the scan count. After an acquisition, this normally reads 100%.

Activity Indicator – During an acquisition, a small window appears next to the status field that shows an animated sine wave. This indicator is active whenever the acquisition status is not “Idle.”

Scans in View – The number of scans displayed across the X-axis.

Pre-trigger Timebase – The pre-trigger timebase in time units per division. This field is blank when no pre-trigger data is currently on the chart.

Post-trigger Timebase – The post-trigger timebase in time units per division. This field is blank when no post-trigger data is currently on the chart.



WaveView Direct-To-Disk Window

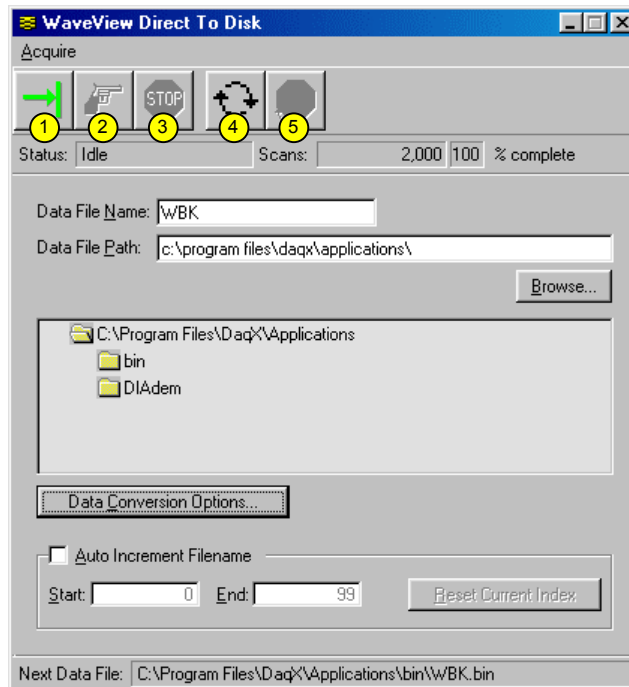

WaveView Direct-to-Disk Window

Item	Description
1	Arm
2	Trigger
3	Stop Acquiring
4	Auto-Rearm
5	Stop Rearming

Control functions in the *WaveView Direct-To-Disk* window are available through the pull-down menu or the toolbar. The figure shows the menu, the toolbar, and each tool button. In addition to the tool buttons, there are status bars that display information about the data file and data conversion:

Status – Indicates the current acquisition state of the WaveBook. If there is no acquisition in progress, the status is Idle. During an acquisition, the status steps through all or part of the following sequence: Configuring, Waiting For Trigger, Triggered, Transferring, Graphing, and then back to Idle.

Scans – During an acquisition, this field displays the current transfer count. Afterwards, it is the total scans in the previous acquisition. A percent complete value is shown to the right of the scan count. After an acquisition, this normally reads 100%.

Activity Indicator – During an acquisition, a small window appears next to the status field that shows an animated sine wave. This indicator is active whenever the acquisition status is not “Idle.”

Data File Name – Displays base filename; allows user to input filename using keyboard or Browse button.

Data File Path – Displays the path of the root data directory. All acquired and converted data is placed in subdirectories of this location. You can press the Browse button to display a tree of all directories available to your computer.

Subdirectory Tree Display – Shows the directory structure of the location where the data files are stored. The presence of data subdirectories in the tree indicates the current data conversion setting. For example, if you see a “DIAdem” subdirectory, you know that your data is automatically converted to the DIAdem format at the end of every acquisition.

Note: If you double-click on a branch of the tree, Windows Explorer opens a folder view of that subdirectory.

Data Conversion Options – Opens a dialog that allows you to set the data file conversion options that WaveView will apply automatically whenever you acquire data.

Auto Increment Filename checkbox – If checked, allows automatic change to the suffix of the Current Filename using the base Filename and the numbers in the “Start – End” range. If not checked, Current Filename will be equal to base Filename. The current Filename is shown at the bottom of the dialog box.

Reset Current Index button – Resets current index and Current Filename to the “Start Index.”

Next Data File - Displays the full path and file name of the next acquisition data file that will be created. This field is most useful when the Auto-Increment feature is enabled since WaveView constructs the filenames by combining the User File Name with the current file increment.

Note: During an acquisition this field displays the path of the file that will be created at the end of the acquisition. With auto-increment enabled, as soon as the acquisition has ended the field is updated to display the name of the next data file that will be created, not the name of the file just created.

In the following sections, menu functions are explained in order of the menu structure. Note that not all menu items have a corresponding toolbar button.

Acquire (Direct to Disk Pull-down Menu)

Arm	Arms the WaveBook to acquire data. Data acquisition will commence as soon as the triggering conditions are satisfied.
Trigger	Issues a Software Trigger to the WaveBook. Whenever the WaveBook is armed and waiting for a trigger, you can take this action to force data acquisition to start.
Stop Acquiring	Ends the current acquisition immediately. All data collected prior to this action will be retained in memory and displayed in the chart control. If auto-rearm is enabled, this action stops the rearming as well.
Auto-Rearm	When enabled, the WaveBook is automatically re-armed whenever an acquisition ends. When this feature is used in conjunction with the Auto-Increment feature, you can create a series of acquisition files with no user intervention. Once armed, the WaveBook will continue to wait for triggers and acquire data unattended until the desired number of acquisitions has been done.
Stop Rearming	With auto-rearm enabled, this action stops auto-rearming but allows the current acquisition to complete. (Pressing “Stop Acquiring” ends the current acquisition immediately.)
Close Direct to Disk	Closes the Direct-To-Disk display and returns to the Configuration menu.

DIAdem® is owned and registered by GfS Systemtechnik GmbH & Co.KG.

Preface 7-2

DIAdem Quick Start 7-3

- Installing DIAdem 7-3*
- Launching DIAdem from an Acquisition Program 7-3*
- Using DIAdem with ChartView 7-5*
- Where to go from here 7-9*
- DIAdem-VIEW Help Files7-9*
- “Examples” Help Files 7-10*

DIAdem - the PC Workshop 7-13

- The Overall Design 7-13**
 - Context Menus and Tool Tips 7-15
 - The DIAdem Devices 7-15
 - The Module Bar 7-15
 - Functions 7-16
 - The Working Area 7-16
 - Dialog Boxes 7-16
 - Default Settings for Functions 7-17
 - Commands 7-17
 - Menus 7-18

- DIAdem Help 7-18**
 - Tool tips 7-18
 - Dialog Box Help 7-18
 - Help Menu 7-18
 - Active Help: Demos and Examples 7-19

- Options 7-19**
 - Desktop Settings 7-19
 - The Device-Specific Settings 7-20
 - Directory Structure 7-20
 - Saving and Loading Settings 7-21

DIAdem DATA: Loading and Saving Data 7-23

- The Data Area 7-23*
- Copying, Pasting, and Deleting Data Channels 7-25*
- Saving and Opening Data Sets 7-26*

DIAdem VIEW: Viewing, Measuring & Editing Data 7-27

- Viewing Data as Graphs 7-28**
 - Graph Definitions: Entering & Deleting Graphs in an Axis System 7-28
 - Using the Graphics Cursor in DIAdem View 7-29
- Using the Cursor Position to Measure a Graph 7-29**
 - Graph Legend: Displaying the Axis-Oriented Display 7-30
 - Global Coordinate Display: Displaying Cursor Coordinates in Overview Format 7-31
 - Axis-local Scaling: Various Graphs in one Axis System for Clarity 7-31
- How to Copy or Delete a Graph 7-32**
- Using Zoom, Scrolling, & Screen Partition 7-33**
 - Zoom: Enlarging Graph Segments7-33
 - Scrolling Through Graph Segments..... 7-34
 - Screen Partition: Re-arranging Axis Systems..... 7-35



DIAdem® is owned and registered by GfS Systemtechnik GmbH & Co.KG. GfS Systemtechnik GmbH & Co.KG maintains the copyright to the material presented in this chapter unless otherwise noted or implied.

Preface

Devices and Interfaces of DIAdem - the PC Workshop

DIAdem - the PC workshop, provides solutions for your technical tasks. It is made up of seven components called devices.



DIAdem® -DATA

DIAdem® DATA manages data sets. Data can be processed individually, in blocks or in channels. Data is displayed for overview in data channels; the corresponding data properties are displayed in sorted table format.

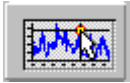

DIAdem® -VIEW

With DIAdem® VIEW you can view data or “look at it under the magnifying glass.” The Working area is divided into several axis systems to facilitate viewing. Curve sections can be deleted and recalculated.



DIAdem® -CALC

DIAdem® CALC lets you evaluate data mathematically. Each mathematical operation can be performed with custom parameters or configured with permanent default settings. Individual calculations are documented in the background in the form of a script.

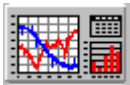

DIAdem® -GRAPH

With DIAdem® GRAPH you can document data in presentation format. Represent your information using graphs, bars, or tables. You can also embed in background graphics.



DIAdem® -DAC

With DIAdem® DAC (Data Acquisition and Control) you can process data online. Measurement and control tasks are described graphically and are divided into four separate layers: the data layer, the Packet Processing layer, the control layer and the system layer.



DIAdem® -VISUAL

With DIAdem® VISUAL your terminal becomes a real-time display instrument. The wide range of indicator and input instruments and the capability of linking in images and image sequences allow you to simulate any number of measurement instruments and situations (real world instrumentation).



DIAdem® -AUTO

DIAdem® AUTO allows you to automate procedures as Autosequences. Procedures can be recorded interactively and then run off any number of times, with results that can be accessed by all the DIAdem® devices. DIAdem® user dialogs enable you to intervene interactively while the Autosequence is running.



DIAdem® Interfaces

DIAdem® has various interfaces for linking external applications: data is exchanged with other Windows applications via DDE and OLE and with databases via ODBC/SQL. External hardware drivers (OPC server) can be accessed via OPC. Via the TCP/IP interface, (measured) data can be exchanged online between DIAdem®-PCs within a network. The DLL interface GPI in DIAdem® can be used to integrate measurement hardware, data file drivers, commands and variables.

DIAdem Quick Start



Reference Note:

DIAdem's **Help Menu**, represented by a question mark (?) in the tool bar contains a great deal of helpful information, including examples and user tips pertaining to all of the DIAdem software features and options.

Installing DIAdem

Minimum System Requirements

- IBM compatible computer 80386, with coprocessor
- Minimum 66 MHz
- At least 8 MB RAM (16 MB RAM or more recommended)
- At least 20 MB of available disk space
- Microsoft Windows (version 3.1, Windows95/98, or WindowsNT)
- Minimum monitor resolution: 800 x 600 pixels

Installation Steps

Note: More than likely you installed DIAdem during the installation of the primary Data Acquisition Software for your device. If you already installed DIAdem, please ignore the following steps.

1. Install Software.

- (a) Insert the install CD-ROM and wait for your PC to auto-access the CD.
- (b) When the *Data Acquisition Software – Master Setup* screen appears, check:

“DIAdem Post Acquisition Data Analysis Program.”

- (c) Click **Start Install**.

2. Choose a DIAdem Installation Type.

You will be prompted to choose a DIAdem installation type.

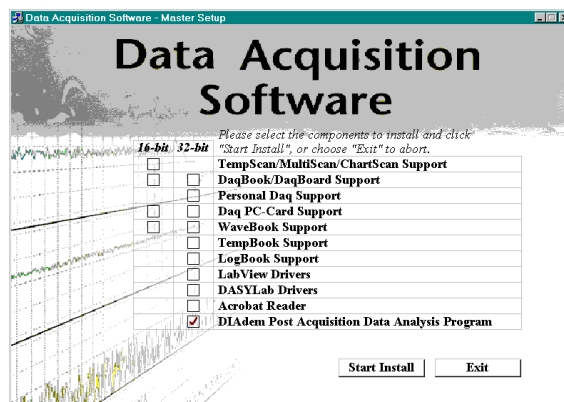

Note: Select one of these two options unless you purchased a licensed version of DIAdem.

- DIAdem Shell + View for IOtech Customers** – Installs a free version with DIAdem Shell and DIAdem View. This version is provided free to users of IOtech hardware.
- DIAdem 30 Day Trial** – Select this installation type if you did not purchase a licensed version of DIAdem, but would like to try out DIAdem's expanded features.

Select one of the above options unless you purchased a DIAdem licensed version. **Do not confuse the “Standard” Licensed version (below) with the DIAdem Shell + View for IOtech Customers version, as these are completely different installs. To install any of the following three “Licensed” versions you must have a license disk and password.** The DIAdem program will inform you when to insert a License Disk, password, and user name.

- DIAdem Licensed Version (Customized)** – Allows you to specify the installed software components for licensed DIAdem.
- DIAdem Licensed Version (Minimized)** – Installs only the program files for Licensed DIAdem. There are no “quick view” or “help files” installed.
- DIAdem Licensed Version (Standard)** – Installs program, “quick view,” and documentation files for a DIAdem licensed version.



If you purchased a *licensed version* of DIAdem, a *license disk* and password were included in your order. The DIAdem install program will inform you when to insert the License Disk and when to enter your license password and user name.

3. Click **<Next>** (after making your selection from step 2).

4. Select Options and Click <Finish>.

Just before the setup is complete, you will see the following two option check boxes.

- Display the latest information now –
This box is checked by default. Leaving the boxed checked brings up the readme file contents listed below. We recommend that you leave this box checked.
- Start the program now –
Launches the DIAdem program for immediate use.

After selecting one, both, or neither option, click <Finish> to complete the setup.

Readme File Contents

Readme file contents are subject to change. File categories are typically as follows:

- Getting Started
- Updates to the Current Version
- Additional Information
- Conditions for Use

Launching DIAdem from an Acquisition Program



The steps in this section do not apply to ChartView.

The following steps can be used with data acquisition programs that contain a file converter capable of converting raw binary data to the DIAdem data format. ChartView User's should skip to the following section, *Using DIAdem with ChartView*.



Reference Note:

The following steps apply to DaqView, Personal DaqView, LogView, and WaveView. The steps are discussed in general terms since the data acquisition programs differ in regard to toolbars, pull-down menus, and other aspects of GUI layout. Refer to your specific application's documentation as needed.

1. Include the DIAdem File Format as a Data Conversion Preference

Verify DIAdem is selected as a file format. This is accomplished through your application's "Conversion Preferences."

Refer to your application's user documentation as needed.

Note: DIAdem is initially selected by default.

File Format	Data File Ext.	Header File ...	Subdirectory
DIAdem	R32	DAT	\DIAdem
ASCII Text (Spreadsheet)	TXT	TX\$	\ASCII
DADISP	DAT	HED	\DADISP

Selecting DIAdem as a File Format

2. Acquire Data to Disk and Convert File

When acquiring data to disk, your application's file converter automatically converts the Raw Binary data to the DIAdem Target Format (verified in the previous step).

During the conversion, a "Converting File" box shows: an animated completion bar, format of the source and target files, and file paths of the source and target. The box is usually on screen for only a moment; however, we can obtain the information from your application's **Data Destination** region, as mentioned in the following tip.

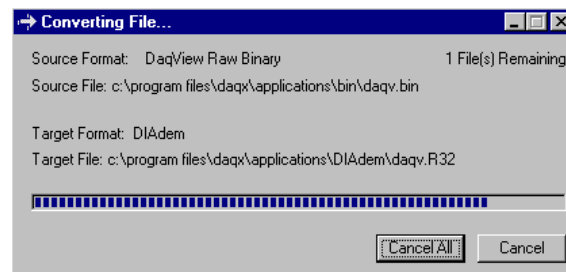

File Conversion in Progress



After the data conversion completes, check the **Data Destination** area of your application. Certain applications, such as DaqView, make use of a Data Destination tab. Other applications (such as WaveView), show data destination after a “Direct to Disk” [or equivalent] button is pressed. Consult your application’s user documentation as needed.

It is a good idea to write down the complete file path for the newly created DIAdem data. This allows you to access the file later from DIAdem’s **Load Data** box, as discussed on page QS-8.

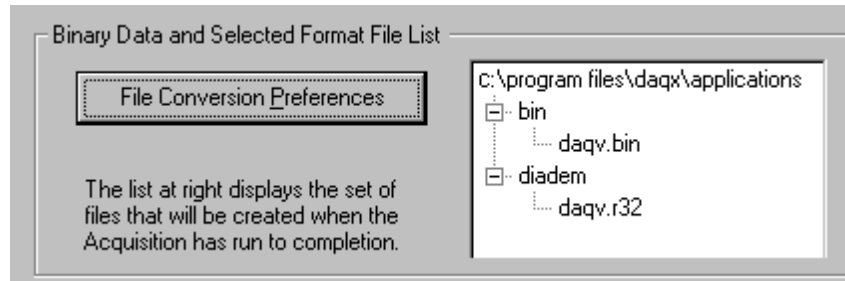

Checking Data Destination

In this example, the DIAdem target file is located at `c:\program files\daqx\applications\diadem\daqv.r32`

3. View Data



From your data acquisition program’s main window, click the **View Data** button. This launches the DIAdem program. DIAdem’s main window will appear with waveforms from the most recently acquired file.

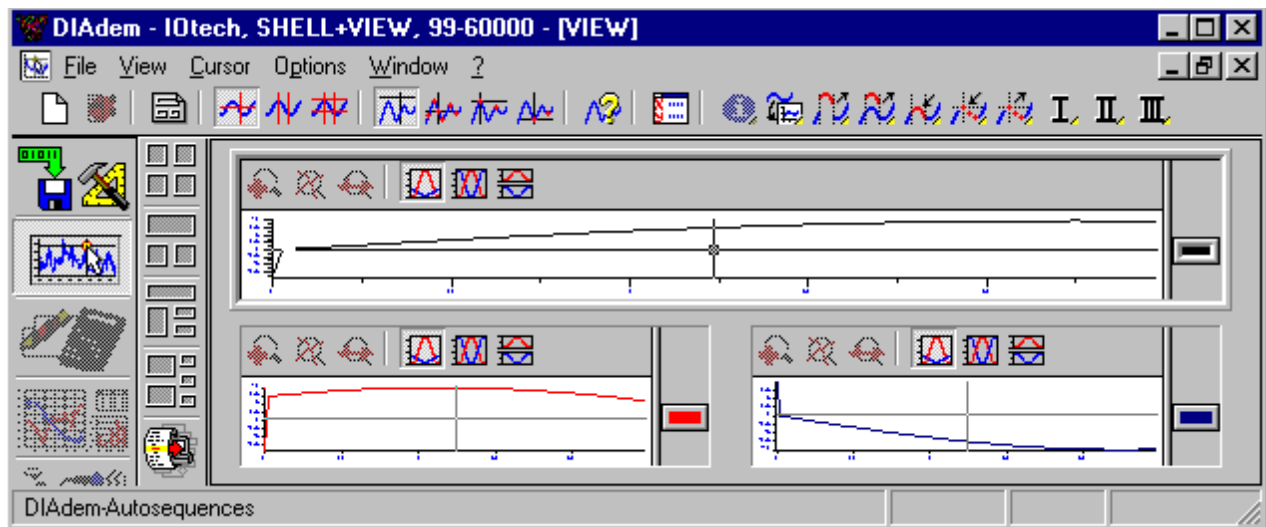

DIAdem’s Main Window, Showing Graphs for Three Channels



We recommend that you review sections 1, 2, and 3 of this document, as well as DIAdem’s help files. The section entitled, “*Where to go from here....*” on page QS-10 includes instruction on accessing the help files and identifies the various help topics.

Using DIAdem with ChartView

This method must be used for data acquisition programs that have no integrated converter capable of converting raw binary data to the DIAdem data format.

ChartView has no direct support for DIAdem. In this case a stand-alone file converter is used to convert binary data to the DIAdem format.

Note: The Data Conversion Utility (file converter) is installed automatically when you install ChartView from CD-ROM release version 1.9 or greater.

The following steps show how to convert a binary file from a data acquisition program to DIAdem format, then load the converted file into DIAdem.

A simplified view of the procedure is at right.

- (A) Use ChartView to acquire and save data in binary [raw binary] format.
- (B) Use the Data Conversion Utility to convert the raw binary format into the DIAdem format.
- (C) Load the converted file into DIAdem.

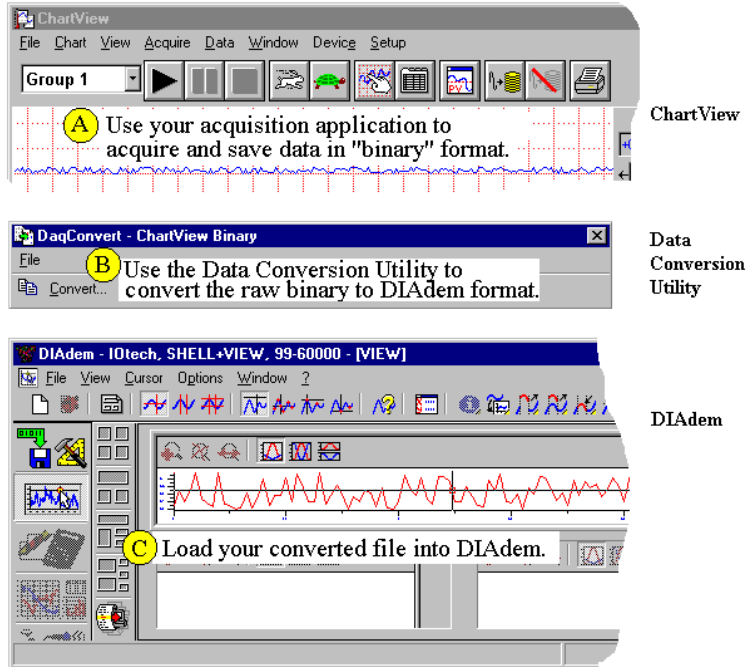

ChartView, Data Conversion Utility, and DIAdem on a Desktop Concurrently

 During a session in which several acquisitions are to be followed by viewing each file in DIAdem, it is recommended that: the data acquisition application, the file converter, and DIAdem remain on the desktop concurrently.

(A) Acquire and Save Data in Binary Format

1. **Open ChartView.**
Consult the ChartScan Users Manual as needed.
2. **Select Binary Data Format.**
This is done in ChartView's **Data Destination** section (see figure).
3. **Acquire and Save Data.**
In the example at the right we are saving a binary data file named **DATA_GG.IOT** to folder **E:\XFER\BIN**

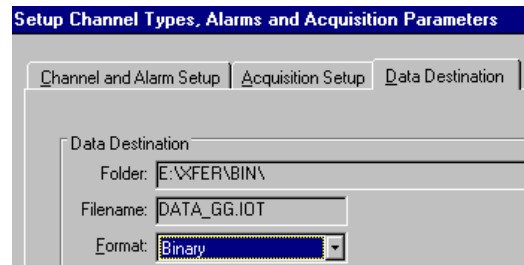

Select Binary Format

(B) Convert Binary Data to DIAdem Format

1. **Open the Data Conversion Utility.**
Use a shortcut icon, or navigate from your desktop's **Start Menu** as follows and double-click on the *Data Conversion Utility* item:

Start ⇒ **Programs** ⇒ **ChartView** ⇒ **Applications** ⇒ **Data Conversion Utility**

The conversion utility appears similar to that shown in the following figure.



Shortcut to the Data Conversion Utility

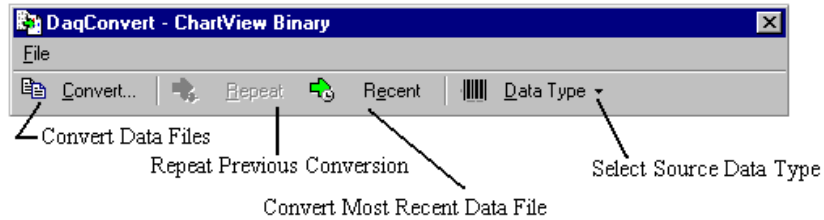

Data Conversion Utility (appearance shown is for ChartView)

2. **Select "ChartView Binary" as the Data Type.**

The first time you run the data converter, a dialog box prompts you to select a data type. The data type designation is based on the program that was used to collect the data, e.g., *ChartView*.

If the prompting dialog box does not appear, use the **Select Source Data Type Tool** to select **ChartView Binary** (as shown in the figure at the right).

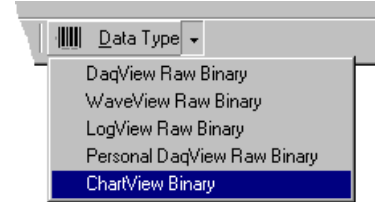

Selecting a Data Type



If this is the first time you are using the data converter you can skip to step 4 since the DIAdem format is initially selected by default.

3. **Select the DIAdem File Format.**

This can be done as follows by dropping down the data converter's File menu and clicking "**Preferences**." This opens a dialog box displaying a list of formats into which your data can be converted.

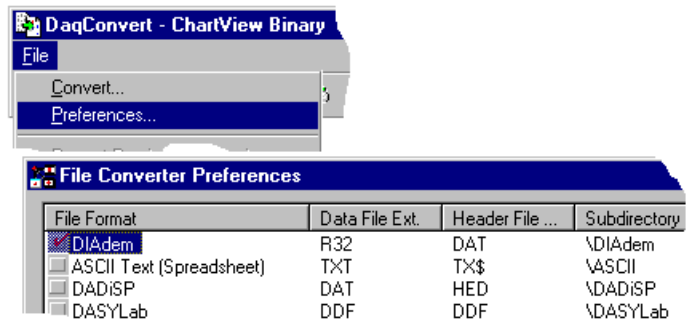

Selecting the DIAdem File Format

If there is not a check mark next to the DIAdem item, click on it once to check it.

Note: You can select additional file formats for other application uses; but for our Quick Start purposes we only need to select the DIAdem format.

4. **Click the Convert Button** [on the data converter's tool bar].

A dialog box will appear that is similar to the **Open File** dialog used by many programs (see following figure). Note that this directory differs for each of the View programs.

If this is the first time that you are converting files of this type, you will have to navigate to the directory containing your data. For example, to get to **data_gg.iot** (as shown in the following figure), we navigated as follows:

E:\XFER\BIN\DATA_GG.IOT Note that this is the path that was identified earlier in our example application's Data Destination for the binary file (on page QS-4).

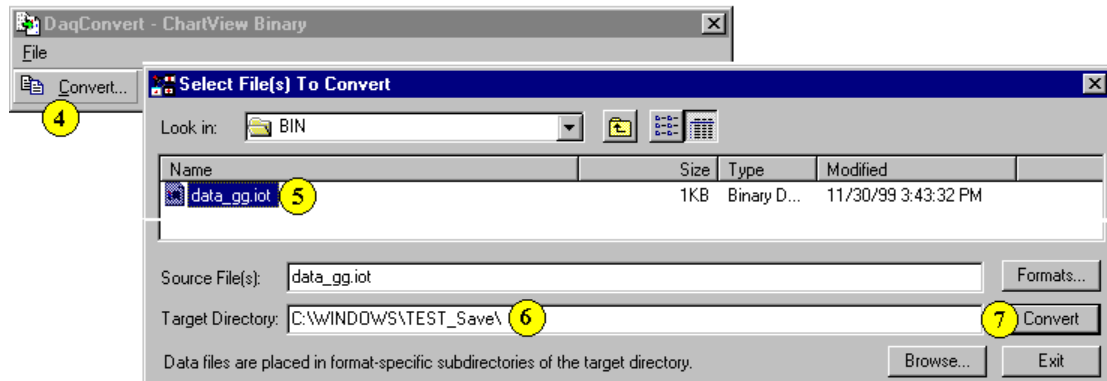

Converting a ChartView Binary File to a DIAdem Format File

5. **Select the Files as you want to Convert.**
 In the example we only have one file available (`data_gg.iot`).

6. **Enter the Target Directory Path.**
 In the **Target Directory** textbox, type the path of the directory that you want to use as the parent directory of the converted data. Note that you can press the **Browse** button to navigate to the target directory instead of typing it.
 In the example above we used: `C:\WINDOWS\TEST_Save\`

The converted data files will be placed in a sub-directory named "DIAdem". Thus the complete path for our saved data is: `C:\WINDOWS\TEST_Save\DIAdem\data_gg.DAT`

7. **Press the Convert Button** (in the Select Files to Convert box).
 This action starts the file conversion and displays a progress meter.

After the *DIAdem* format file has been created, we can load our acquired data into *DIAdem* as discussed in the following section.

(C) Load the Converted File into DIAdem (these steps are not exclusive to ChartView and can be applied to other acquisition programs)

If you do not already have *DIAdem* open, launch the program from a desktop shortcut (if applicable), or by navigating from the PC desktop as follows:

Start ⇒ Programs ⇒ DIAdem ⇒ DIAdem

1. Click the **DIAdem-DATA: Data Management** button.
2. Click **Load Data**. A Load Data box appears.
3. Using the *Load Data* window, locate your *DIAdem* target file and highlight its name.
 In the example we have highlighted `daqv.DAT`.

Note: We reached this target file by navigating as shown in steps A through E (below).

We used the **Target Directory** path we created earlier `C:\WINDOWS\TEST_Save\`

The complete path for our saved data was `C:\WINDOWS\TEST_Save\DIAdem\data_gg.DAT`

Note: *DIAdem* data files always have a "DAT" file extension. The file name itself will match the name of the raw binary file you converted.

If you need help finding a target directory path, see the related tip on page QS-3; or consult your application's users manual, if needed.

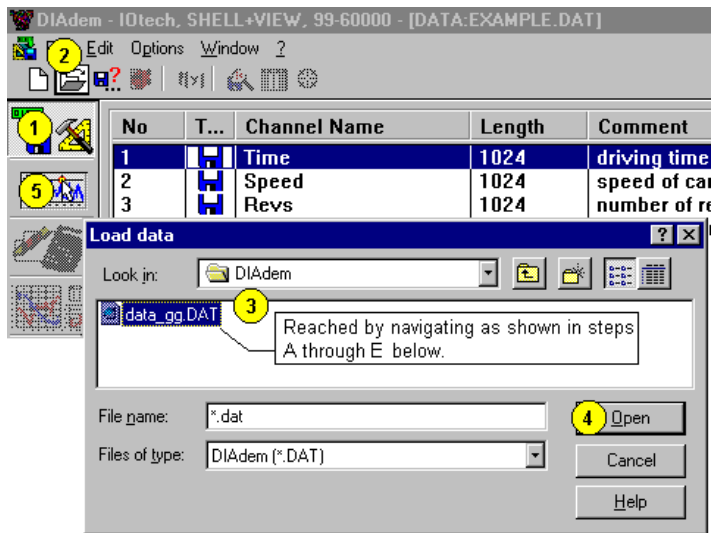

Loading Converted ChartView Data into DIAdem

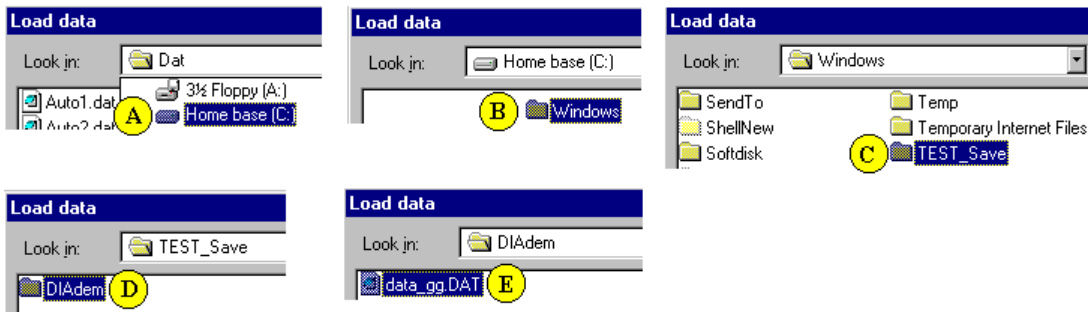

Navigating via DIAdem's Load Data Box to Locate the Target File

- Click **Open**.
- Click the **DIAdem-VIEW: Data Viewing** button.
- Right-click in the empty graph region of a chart. A specific location is not required.
- Click on the **Graph Definition** item listed at top of the pop-up box. A *Graph Definition* box appears, as shown in the following figure.

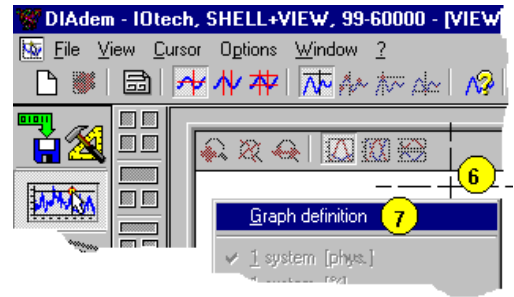

- Click **New Entry**. A *New Graph Definition* box appears.

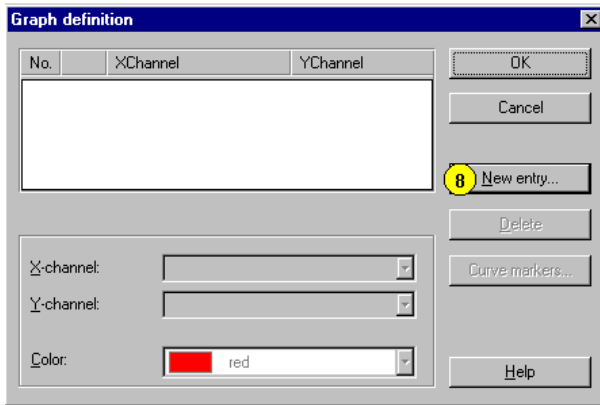

Selecting "New Entry"

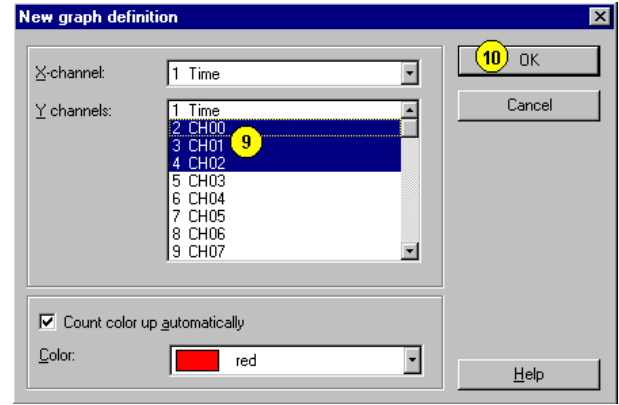

Selecting Three Channels for Viewing

- Select three channels. Do this by holding down your keyboard's **CTRL** key, then selecting three channels with the mouse. In our example we have selected Channels 0, 1, and 2 (CH00, CH01, CH02).
- Click **OK**. A *Graph Definition* box appears with information regarding the three graphs. For each graph (1, 2, and 3) the X-axis and Y-axis are identified and a graph color is indicated as shown in the following figure.

In the *Graph Definitions* example to the right, we see that the X-axis represents time and the Y-axis represents channel values.

- Click **OK**.

The three graphs can now be viewed as indicated in the following two figures.

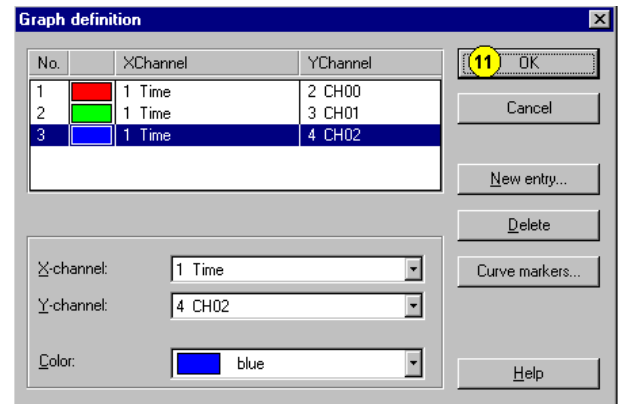

Graph Definition for 3 Channels

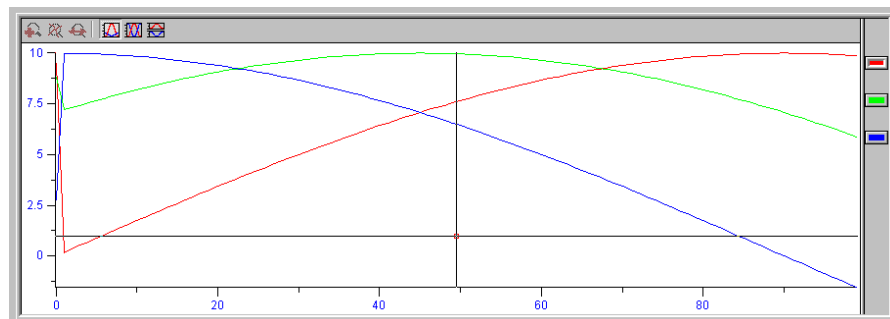

Viewing Three Graphs of Channel Values over Time

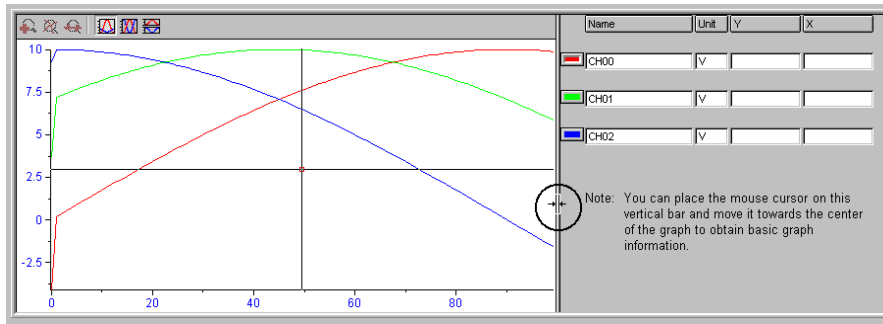

Viewing Three Graphs and Basic Graph Information

Where to go from here ...

At this point you should have just completed viewing data in DIAdem. What's next?

We recommend that you experiment with the program to get a better feel for its many features and capabilities. You should review the available documentation, including the DIAdem Help files. Several help topics are identified in the remaining figures.



Reference Notes:

- (1) Refer to the sections 1, 2, and 3 of this document for more detailed information regarding DIAdem.
- (2) DIAdem's **Help Menu**, represented by a question mark (?) in the tool bar contains a great deal of helpful information, including examples and user tips.

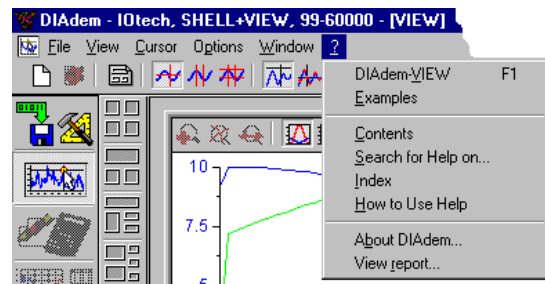

Accessing DIAdem's Help Files

DIAdem-VIEW Help Files

Selecting **DIAdem-VIEW** from the **Help pull-down menu** provides quick access to the following help topics. You can also use your keyboard's **F1** key for immediate access to the topics identified below.

Introduction to DIAdem-VIEW

[Working with DIAdem VIEW](#)

Function groups of DIAdem-VIEW

- [Loading a new screen partitioning](#)
- Deleting all graph definitions
- [Crosshair, Band, Frame cursor](#)
- [Free, Graph, Maxima, Minima cursor](#)

Features and tasks of DIAdem-VIEW

- [Adding a new graph in an axis system](#)
- [Displaying/suppressing the display of coordinates](#)
- [Copying, moving and deleting graphs](#)

[Working with DIAdem-CALC](#)

- Enlarging graph segments
- [Legend display / Display of graph coordinates](#)

[Legend display / Display of graph coordinates](#)



[Icon which can be assigned to any autosequence](#)

The first 6 symbols are pre-set by default. Information on the assigned autosequences can be obtained from



[End interaction](#)

Other tasks and features (only accessible from the menu bar)

Cursor ...

[Set the guide graph](#) Defining the graph to which the graphics refers

Settings ...

[General](#) Data format, brief help, channel properties

[Parameter file](#) Parameter file for default settings of the DIAdem actions

[Memory organization](#) Size and organization of the data storage area

[Report](#) Confirm report file

See also:

[DIAdem Cursor Types](#)

“Examples” Help Files

Selecting **Examples** from the Help pull-down menu provides quick access to the following help topics.

Examples and Demos ...



[How to use DIAdem](#)



[Applications](#)



[Templates](#)

How to use DIAdem



[Loading, processing and calculating data](#)



[Viewing Data](#)



[Data Calculation](#)



[Create Presentation Graphics](#)



[Creating Block Diagrams, Measurement and Visualization](#)



[Creating Autosequences and Starting](#)



DIAdem - the PC Workshop

DIAdem[®] has been designed as a PC workshop for solving technical tasks. The underlying principle is a logical arrangement which gives you an overview of all program elements. Individually encapsulated devices ensure an orderly division of tasks. Similar functions are grouped together and parameters in dialog boxes are hierarchically ordered according to their importance.

Three guidelines determine the nature of DIAdem[®] from the most basic layer up: *functionality*, *clear layout* and an *intuitive interface*.

Functionality means that DIAdem[®] allows you to manage, analyze and document your data with consistent operating logic. All similar functions have been grouped together into complete units, the DIAdem[®] devices. All mathematical analysis functions are found in the optional DIAdem[®] CALC device, all functions for creating graphic documents in the optional DIAdem[®] GRAPH device, etc.

This brings us to the second concept, DIAdem[®]'s **clear layout**. As a rule, only the device which is currently being used is visible. The others remain in the background. The surface layer of a device is designed so that only the functions required for the task at hand are visible.



Symbolic interface

The third concept, **intuitive interface**, makes it easy for you to use DIAdem[®]'s full range of features. All features can be activated by graphic symbols (icons). You can also make changes to an axis system directly on-screen with the mouse. And context menus accessed by clicking the right mouse button bring up context-specific menus, making it easy to set parameters for an object.

This document is an abbreviated manual designed for rapid familiarization with the free DIAdem-VIEW device. More detailed information is available in the DIAdem User's Manual that is distributed with Licensed-Versions of DIAdem.

Note that all available DIAdem[®] functions are explained in the program's online help.

Throughout the manual, you will see sample tasks you can execute with DIAdem[®]. The steps demonstrate typical examples of the kind of work you can perform with each device.

Sections you can perform on your own computer are printed in italics.

The Overall Design

The structure of the screen is based on a consistent operating logic. In the following figure you will notice that the Device and Module Bars (used to access functions) are arranged vertically, whereas the operating elements of the Function Bar are arranged horizontally. Common operating elements are always visible.

The following screen view and detailed description [of the individual structural and interface elements] illustrate the design of a DIAdem[®] PC workshop. The description begins at the left edge of the screen with the Device bar, moves right to the Module bar, then to the Function bar and up to the Tool bar and Menu bar.

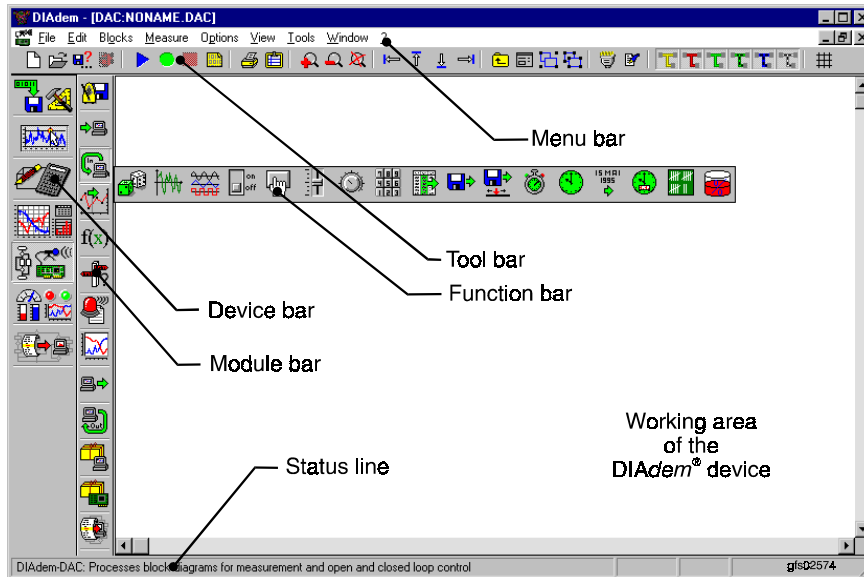

The DIAdem® devices are lined up one under the other on the left side of the screen, where they are always accessible. Each of the individual DIAdem® application windows is known as a device. They represent the topmost layer in the arrangement of PC workshop. The **Device bar** is always visible, making it easy to move from one device to another.

When you choose a device by clicking on it with the mouse, the corresponding **Module bar** appears for most devices. On this second layer, functions and actions are grouped thematically.

After you click on a button on the Module bar, the corresponding **Function bar** opens up horizontally. You can perform functions such as choosing an axis system and tables in the optional DIAdem® GRAPH device or choosing mathematical functions in the optional DIAdem® CALC device. Functions are processed in the **Working area** of each device.

Note: When symbols appear *grayed-out* in the Function bar, Module bar, or Device bar, the corresponding function, option or device is not part of the current installation. Devices and options can be included at any time.

The horizontal **Tool bar** is located above the Working area. It contains all the features and commands you will need to use DIAdem® in the Working area.

You can also access all the features, functions and commands of the currently active device in the corresponding menus through the **Menu bar** with the keyboard.

You should also be familiar with the **Status line**. In addition to general messages, brief help messages appear here describing each symbol or function. For example if you are working with an axis system in the optional DIAdem® GRAPH device, you can tell [from the Status line] which item is used to move an object.

Context Menus and Tool Tips

Two important elements do not appear in the screen above, since they are not normally visible: context menus (sometimes called shortcut menus) and tool tips.

Context menus provide rapid access to the most important features. You can access them by clicking on the right mouse button from many places in the program. For example one context menu offers features used in working with the active axis system in the optional DIAdem[®] GRAPH device.

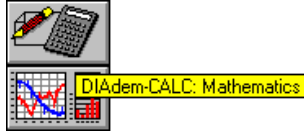

Tool tips

Tool tips are text fields used to identify symbols. A tool tip appears whenever the mouse pointer momentarily rests on the corresponding symbol.

You can use Tool tips to familiarize yourself with the individual devices. To activate a tool tip, slowly move the mouse pointer over the Device bar without pressing a mouse key.

The DIAdem Devices

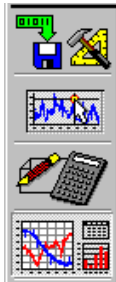

Part of the DIAdem[®] Device Bar

The DIAdem[®] devices could be thought of as a set of work tools. Each tool is intended for a specific purpose. Note that devices can be easily distinguished by their graphic images (icons).

The element common to each of these devices is the data, which is processed in different manners by different devices. In our analogy, the data is then the work object on which the tools are used. Data must first be available to be processed by the devices.

There are two types of devices:

- devices that can create data, for example, the optional DATA and optional CALC devices
- devices that merely display data, such as the VIEW device and the optional GRAPH device.

The optional Autosequences represent a special case, as they can use features from all the devices, in order to automate work sequences.



Mouse pointer

To select a device, simply click on the corresponding symbol in the Device bar with the left mouse button. For example to choose the optional DIAdem[®] GRAPH device, if applicable.

Note:

Whenever you are told in this manual to activate, click on or execute a feature, device or object, it means you should click on the appropriate symbol or object with the *left* mouse button. Similarly, “double-clicking” and “pressing a button” refer to the *left* mouse button.

The Module Bar



DIAdem[®] GRAPH
Module Bar

When you select a device, the Module bar, another vertical bar, appears to the right of the DIAdem[®] Device bar. Similar features and functions are arranged together in groups on this bar.

For the optional DIAdem[®] GRAPH device, this means that the symbols for individual graphic modules are found here: axis system, tables, and background images to name a few.

For the optional DIAdem[®] CALC device, the mathematical formulas are grouped together on the module bar: basic math functions and features for signal analysis and statistics.

Functions

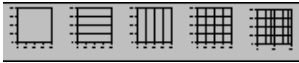

Part of Function bar for 2D axis systems in DIAdem® GRAPH

When a group symbol is activated, the corresponding Function bar opens up horizontally. Executable functions are for example choosing an axis system and tables in the optional DIAdem® GRAPH device, or choosing mathematical functions in the optional DIAdem® CALC device.

If you have the optional DIAdem® GRAPH device, choose one of the various 2D axis systems in by clicking on the corresponding symbol in the Function bar.

The selected axis system is indicated in the upper left-hand corner of the Working area. The function bar is the same in all the DIAdem® devices. Autosequences that are used frequently can be assigned to these symbols and are thus available in all the devices.

The Working Area

When you select a device the Working area is automatically filled with a pattern. The same procedure is always used for working with objects: a left-button mouse click is used to activate, left double-click to set parameters and right mouse click to open context menus.



Mouse pointer

If you have the optional DIAdem® GRAPH device, click on one of the 2D axis systems.

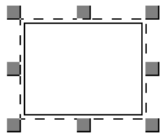

Marking a frame around an object

You will notice light gray marking at the corners and at the middle of each side of the active axis system. If you click inside the markings again and hold the left mouse button down, you can move the axis system.

When you “pull” on one of the marks, the axis system increase in size correspondingly. You can pull by clicking with the mouse and holding the left button down while you move the mouse. If you pull the marks on the sides, the axis system will increase in size horizontally or vertically. If you pull on a corner mark, you will zoom the entire axis system.

Dialog Boxes

All settings for objects are handled in dialog boxes.

Generally dialog boxes are used to associate data with objects such as axis systems or tables, or to set properties such as line style and color.

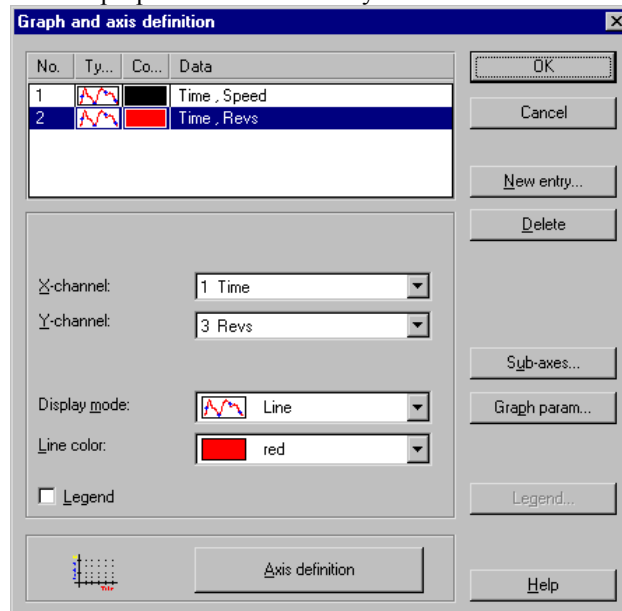

To access graph and axis definitions in DIAdem®-GRAPH, **double-click** on the axis system in which you wish to represent the data.

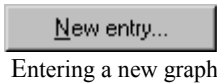

To enter a graph, use the New entry button. At this point it will be sufficient to specify from the list of available data channels an X channel to represent data values on the X axis and a Y channel to represent corresponding values on the Y axis. Exit the sub-dialog box and the main dialog box with the OK button.

Note: In the “graph entries heading” of above mentioned dialog box , the word “Color” is not complete [it appears as “Co...”]. As soon as the mouse cursor crosses the vertical line separating the columns "F..." and "Data," the cursor appears as parallel lines with arrows to the left and the right. You can use this cursor to expand the column, allowing you to read "Color" [instead of “Co...”].

Graph and axis definition is a rather complicated example of a dialog box, but it illustrates well the concept of hierarchy in dialog boxes.

Basic options that are often changed are at the top of the dialog box hierarchy. In the graph and axis definition, for example, a quick glance reveals which data channels are represented and how. These can be changed directly on the top layer.

Less common options are located one layer “deeper“ to allow room for the essential ones. They can be reached by a button. Standard features such as OK, Cancel, Delete, Change, and Close are also accessed by buttons. The Help button is always in the bottom right-hand corner. It provides explanations of the individual dialog parameters.

Default Settings for Functions

The properties of any object can be changed at any time and maintained in a diagram or block diagram (see the explanation of dialog boxes above). These settings, however, apply only to the object at hand or the mathematical function which has just been called. The next time the mathematical function is called, the default setting will appear again. To change settings permanently, use Default setting.

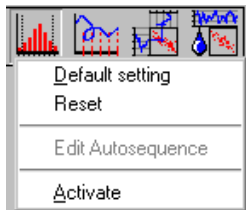

Default setting on the function bar (use right-mouse button)

To reach the default settings for a function, click on the Function bar with the **right mouse button** (for example on an analysis symbol in the optional DIAdem[®] CALC device). A context menu appears which includes the **Default setting**. Activate this menu item with the left mouse key, and the appropriate configuration dialog box will appear.

After you exit with Save changes, the changes you have made to the settings will become permanent. In the optional DIAdem[®] GRAPH device you can change default settings for axis systems, tables, and background graphics; in the optional DIAdem[®] CALC device all mathematical functions are affected. In optional DIAdem[®]-CALC, the standard settings of the functions can be reproduced with “Reset.” The related action can be executed with “Activate.” The function bar for the Autosequences can be assigned an Autosequence using “Default” and it can be removed with “Delete default.” The Autosequence currently assigned to the icon can be edited by clicking “Edit.”

Note: The altered default settings are automatically written into the Desktop file in DIAdem[®] and thus saved. When the default settings of an action have been altered, they no longer affect objects that have already been used in a diagram or block diagram!

Commands



Part of the DIAdem[®] GRAPH Tool bar

The Tool bar which extends horizontally above the DIAdem[®] Working area contains the commands you will need most commonly for working with any of the DIAdem[®] devices. Some of these are basic commands such as Delete, Open and Save as; others are device-specific commands. The most important commands in the optional DIAdem[®] GRAPH device are: Print, Output to clipboard, various commands for aligning objects to each other, the magnifying glass and Sketch presentation. Most important in DIAdem[®] VIEW are graph definitions and various types of cursors.



Sketch Mode in DIAdem[®] GRAPH

Activate an object in DIAdem[®] GRAPH. As soon as you press the Sketch mode button, the object is faded out and is represented only by a place holder.

Symbolically representing objects as rectangles makes it possible for you to work with them quickly and easily even in diagrams containing numerous objects.

Menus

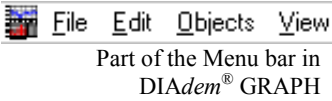

All of the functions and commands needed for any device in which you are working are found in text format in the Menu bar located above the Tool bar. In these menus any feature can be accessed and executed via the keyboard instead of the mouse.

Use the <Alt> key to access the Menu bar. Then type the underlined letters for individual menu items on your keyboard. When a second menu opens up, choose a feature from it and execute it directly by again typing the underlined letter for the desired menu item.

Note: You can also use arrow keys to select a menu item and execute it with the <Enter> key.

DIAdem Help



Use DIAdem® Help to explain, describe and clarify the program. There are three separate types of help in DIAdem®: Tool tips for the user interface, context-sensitive help in dialog boxes, with explanations of all parameters, and the Help menu with explanations grouped by subject matter.

Tool tips

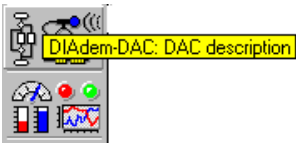

Tool tips

You have already used Tool tips several times during the description of the DIAdem® interface to learn the meaning and function of a symbol. Bring up Tool tips by letting the mouse pointer rest for a moment on the unknown symbol. A yellow “banner” soon appears with a brief explanation of the symbol.

You can choose **long Tool tips** in the Options menu (under General). Then the function of a symbol will be described with more than just one word.

Dialog Box Help

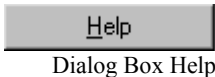

Dialog Box Help

Dialog boxes are used whenever the settings for an object need to be precisely adjusted. You can get context-sensitive help for dialog boxes and parameters in them by pressing the Help button found in any dialog box. Dialog box Help explains each of the parameters in the open dialog box, and what parameters lead to what results. More complete explanations and related topics are available through references.

Help Menu

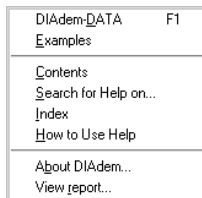

The DIAdem® DATA Help menu

To reach the Help menu, use the question mark in the Menu bar. In the Help menu you will find a description of the active DIAdem® device, the contents of the main Help subjects, Search for Help on... and View report.

The first line of the Help menu is reserved for a description of the **Device** currently running. In the Help menu to the left, this is DIAdem® DATA. Descriptions of devices are arranged so that the design and functionality and characteristics of each DIAdem® device are discussed first; then you learn how to work with the device.

You can access the main Help file in DIAdem® through **Contents** in the Help menu. Working with DIAdem® in general and the DIAdem® devices in particular are described here. These explanations are intended for the user who wants to learn the basics about the design of the program and how to use it.

On the other hand, if you need to learn something about a specific concept or a special topic, use the menu item **Search for Help on...** Enter a search concept. Then choose from the list of subjects the one which best answers your question. The **Glossary** is especially useful as a source of DIAdem® definitions.

The **Report** is a DIAdem[®] record of the previous DIAdem[®] sessions with the start and finish of each work session, along with error messages and warnings and the corresponding dates and times. You can find out more about the nature and meaning of these messages from Report in the Options menu. You can also delete the report there.

Active Help: Demos and Examples

The examples and demos are in general intended as solutions to specific tasks in a DIAdem[®] device. You can start these examples directly from DIAdem[®] Help.

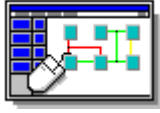

Sample demos in Help

Click on the question mark in the Menu bar, then choose Examples. Click on a device symbol to go directly to the list of corresponding examples.

With the examples, there are differences in the level of complexity between the demo sequences, applications and templates. The demo sequences are short film sequences, which present the creation of a graphic DIAdem[®]-GRAPH, for example. The applications and templates demonstrate not only the spectrum of application for the program, they can also be used as the basis for your own (partial) solutions. For this purpose, press the info button  before the particular example, for a display of a task description and the files used.



Start Example

The Start button is used to start the example; and <ESC> cancels the display, measurement, or Autosequence.

To use a demo you have opened as a pattern, save it under a new name in the user directory (..\diadem\user\dac). Since these solutions are not directed towards specific tasks, you can use them as building blocks in material you are working on by transferring them with the clipboard.

Copy and Insert

You can mark the entire display or block diagram with <CTRL + A>. To select a portion of either, expand the blue frame to the desired dimension while holding down the left mouse button. Then you can copy the selected portion to the clipboard with <CTRL + C> and insert it back into another block diagram in the Working area at the position of the mouse cursor with <CTRL + V>.

Options



Desktop Settings

The various program settings in DIAdem[®] can be accessed via the “Settings” menu. The “Desktop Parameters” include all the workshop-related settings such as the menu points *General*, *Parameter file*, *Device-specific*, *Memory organization*, *GPI-DLL Registration* and *Report*. In the single devices, you will also find device-specific settings such as the hardware assignment and packet processing, or the page layout (in the optional DIAdem[®]-GRAPH device) to name a few.

Desktop Settings

General Settings

The Desktop settings include the **General Settings**, such as those for program behavior (warnings, warning tone for errors, long Quickinfo), for the data format and channel characteristics as well as the selection of other ASCII editors, in particular for the Autosequences.

The path selection (see Directory structure) and the specification of the standard files to be loaded for all the DIAdem[®] devices are made in the sub-menu with the same name. Although the library paths can only be altered using the settings, DIAdem[®] retains the path the last file was loaded from as the user path, for each device.

Device-specific

Device-specific settings include, for example, specifying the memory form in DIAdem[®]-DATA, the ASCII data and the data checks.

Note: Another start file can be entered here. By the way, if no file name is entered here, no template will be loaded in the appropriate device!

- Memory organization The **organization of the memory area or data area** can only be altered when no DIAdem[®] device is active. This means that all the DIAdem[®] devices can be closed with the window menu with "Close all". As soon as only the SHELL is displayed, the size of the data area can be increased or decreased. For these settings to become effective, DIAdem[®] has to be restarted. This is performed automatically if you affirm the appropriate request.
- Define Report The **Report** contains a record of the DIAdem[®] program start and finish, error messages and confirmation messages. The extent of the Report, as well as the associated Editor, with which the memory format is selected, can be defined.

The Device-Specific Settings

Depending on which DIAdem[®] device is open, other settings specific to this device also appear with the Desktop settings, such as, for example, the page layout and the color palette in the DIAdem[®]-GRAPH device. They are explained briefly in the following.

Directory Structure

When you install DIAdem[®], the setup program creates the directory structure shown below on the path you enter. This structure consists of three directory layers.

Standard directory structure

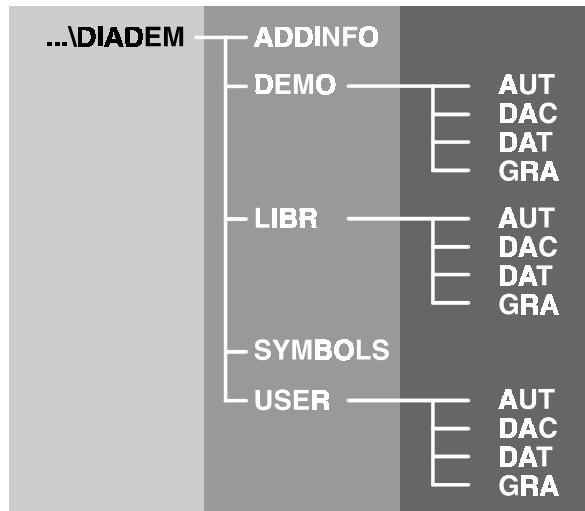

- I. In the **Program directory** (e.g., c:\diadem) you will find the program files (*.exe, *.dll), control files and others such as the Readme file.
- II. The first sub-directory layer serves to organize the remaining files (ADDINFO, DEMO, LIBR, SYMBOLS and USER).

You will find all the practice examples from the manual and the patterns (example.*) in the DEMO directory. These can be used whenever you start the program. The library directory LIBR contains all the examples and demos which can be started from Help (you choose during installation whether to install these). Neither the demo files nor the Libr files should be changed by individual users. Instead personal copies (which *can* be changed) should be stored in a personal directory, for example USER1, etc. This is especially important when you run DIAdem[®] on a network. The LIBR, SYMBOLS and ADDINFO sub-directories contain systems files necessary for DIAdem[®]. They should *never* be changed.

The user path can be changed using the Autosequence "ChDir", which is connected to the twelfth function symbol. This applies globally, i.e. the same for all the DIAdem[®] devices.

III. The individual files are located on the second sub-directory layer, each in the appropriate directory:

- AUT** Autosequences (*.aut), compiled Autosequences (*.auc), list files (*.lst), variable definitions (*.vas), user dialogs (*.cod),
- DAC** Block diagrams (*.dac), sub-block diagrams (*.sub), control file (*.atr), message file (*.asc)
- DAT** Data header file (*.dat), data file (*.r48, u.a.)
- GRA** Picture definition (*.lpd), meta files (*.wmf)

Saving and Loading Settings

While you are working with DIAdem[®], you will have to modify the standard settings according to your requirements. The program settings are stored in the Desktop file (**desktop.ddd**). When you leave DIAdem[®], modifications are registered and you are asked if you want to save them. You should save your personal settings in your own Desktop file, so you don't lose them.



Save Desktop under
New Name

First close all the DIAdem[®] devices with "Close all " in the "Window" menu. Don't worry: the contents of the window are retained, even if they have not yet been saved. Then click to the diskette symbol in the command line. Now you can save your settings in a new Desktop file.

In order for them to take effect, DIAdem[®] is now automatically shut down. You will now be asked whether the files are to be saved and DIAdem[®] will start again with your settings.



Load Desktop file

DIAdem[®] starts with the Desktop file desktop.ddd. If you are working on various projects, which require varying settings in DIAdem[®], they can be saved in various Desktop files. The associated Desktop file is then to be loaded with each project. Don't be startled when DIAdem[®] is restarted. This is necessary in order for the settings in the newly-loaded Desktop file to take effect.



DIAdem Data: Loading and Saving Data

The functions of DIAdem® DATA available with the DIAdem®-SHELL allow you to manage data: you can open and save data, and import external data. Data is organized in channels, with each channel representing an independent series of data. The data may originate directly from measurement by an external device connected to your PC or may be in file format. All the DIAdem® devices use the data in the Data area.



DIAdem® DATA

No	T...	Channel Name	Length	Comment
1		time	1024	driving time
2		speed	1024	speed of car
3		revs	1024	number of revolutions
4		torque	1024	course of torque
5		accel_time	1023	Input: time (1), speed (2)
6		acceleration	1023	Input: time (1), speed (2)
7		accel_smoothed	1023	Input: Y_Diff (6)
8		conv_speed	1024	ch(conv_speed)*3600
9			0	
10			0	
11			0	



The DIAdem® DATA Tool bar

The DIAdem®-DATA Tool bar allows you to open and save data files and delete all files in the Data area.



Access context menus with the right mouse button

The DIAdem®-DATA Working area gives you an overview of open data channels. From the Working area you can cut, copy, paste or delete data channels.

Context menus play an important role in DIAdem®-DATA. Different functions appear in a menu depending on whether you click the right mouse button in the data overview or in the Channel contents.

The Data Area

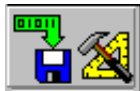

DIAdem® -DATA

Select DIAdem® DATA by clicking on the corresponding button on the Device bar.

An overview in table format appears in the Working area, representing the data channels currently open in the Data area. This overview includes the name, index number, and other information such as the length and type (origin) of each data channel. You can make the columns larger or smaller as you wish to enhance readability. Simply move the column dividers in the Title bar by holding down the left mouse button.

You can see key information on your stored data at a glance in the Channel overview

No.	T...	Channel name	Length	Maxim...	Comment
1		Time	1024	2048	Driving time
2		Speed	1024	2048	Speed of the car
3		Revs	1024	8192	Number of revolutions
4		Torque	1024	2048	Course of torque
5		Formula results	1024	1048576	sin(ch(3))
6		Formula results	1024	1048576	cos(ch(3))
7		Temperature_1	1024	8192	Acquired channel
8		Temperature_2	1024	8192	Acquired channel
9		Temperature_3	1024	8192	Acquired channel
10			0	2048	
11			0	2048	

You can alter the appearance of the data overview by changing the order of the columns. Select Data overview in the Options menu. The clicked line can be moved with the Up and Down buttons. Confirm with "OK" and the column order will be altered accordingly.

Using Options
to move lines

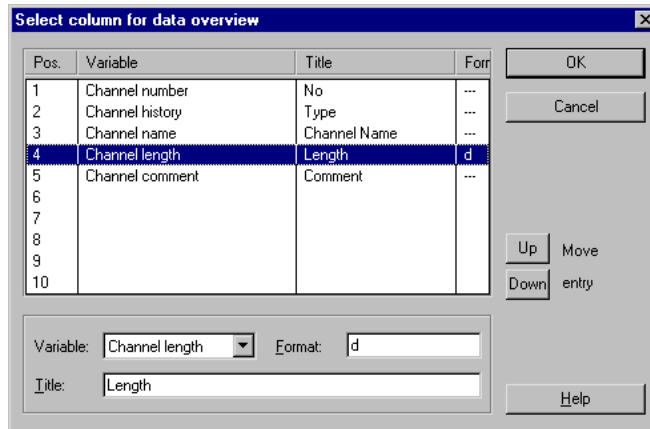

Data Resources

Data may originate from various sources. In the illustration above, various symbols and descriptions represent the origin (type) of data in the column under T... (Type): Data which has been input, read in, calculated and measured, or is “free.” Free channels do not yet contain any data.

Channel lengths and
number of channels

Data in DIAdem[®] is organized into channels. A data set may contain several data channels, which may be of unequal length. Each individual channel represents a series of logically connected independent numbers. The maximum channel length and the maximum number of channels are practically unlimited, since up to 2 billion values are possible. The resulting data matrix is dynamically adjusted to the current data stock. If more channels arise than were preset, DIAdem[®] extends the data matrix accordingly. The channel length is also dynamically extended to the actual number of values. The channel length and the number with which DIAdem[®] is to be started is specified in the “Options” menu at the DIAdem[®] main level (i.e. if none of the DIAdem[®] devices are open) in the menu point “Memory organization - Data area.” As this involves a complete reorganization of memory, these alterations do not become effective until the program is automatically restarted.



The Data area exists only at program runtime! Manual changes to the Data area are temporarily registered, but are not permanently stored until the data set is stored on your hard drive. Data sets to which changes have been made should be saved under a new name so that the original data is still accessible.

Sample Data Set

The data opened by default was acquired during an automobile test drive. Included are the driving time, speed and the motor rpm and torque.

If you have already made changes in the Data area after starting DIAdem[®], open the sample data set ‘data.dat’ from Open in the File menu. For more information on opening files, see the end of this chapter.

Copying, Pasting, and Deleting Data Channels

Not only does the Working area in DIAdem® DATA offer you a data overview; you can also copy, paste and delete data channels in the Working area. You can perform these operations on individual channels or on groups of channels.

Marking multiple channels *Mark all four channels by holding down the left mouse button and dragging the mouse over the desired channels.*

You may also mark the first data channel by clicking with the mouse and then clicking on the last channel while the Shift Key is held down. You can mark separate, non-contiguous data channels in the same manner: click on the channels with the left mouse button while the Control Key is held down.

Cutting and pasting channels Click on the right mouse button. Choose the option “Cut” from the Context menu. After confirmation the marked channels will be deleted from the Data area and copied into the Windows clipboard. Click with the mouse on the second line of the channel overview. Paste in the contents of the clipboard with **<CTRL + V>**.

Cut channels are pasted in from the Windows clipboard at the marked location.

In this case that leaves a free channel in the first line of the Working area.

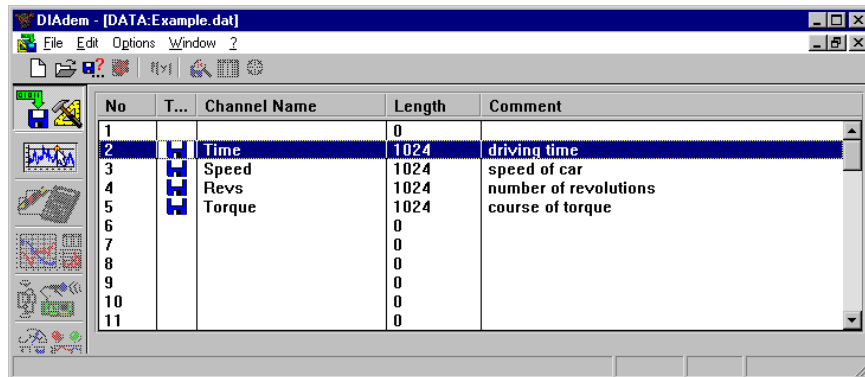

No	T...	Channel Name	Length	Comment
1			0	
2		Time	1024	driving time
3		Speed	1024	speed of car
4		Revs	1024	number of revolutions
5		Torque	1024	course of torque
6			0	
7			0	
8			0	
9			0	
10			0	
11			0	

Saving and Opening Data Sets

Data in the Data area is only present during program runtime. It is deleted as soon as a new data set is opened in DIAdem® DATA or when the program is terminated. To use this data in the future you must save it to the hard drive.



Save Data as...

To save the data set, click on the corresponding symbol in the Tool bar. Save the edited data set to the demo path (...\\diadem\\demo\\dat) under the name example1.dat. The data set can also be saved directly with its name, using the file menu.

A bit of theory: as soon as you have saved data, DIAdem® stores two files with the same names on the data path: the actual data file, usually with the extension *.R32, and the associated header file with the extension *.DAT.

The **header file** contains all the information required to open the (numeric) data files. The header file contains not only the general data set description, but also all the information required to read in the single channels of the data file(s). The **data file** contains the numeric data, saved in one or more channels.



Delete all data

The whole data area is emptied with the “empty page” symbol in the tool bar. In the following, the example file “Data.dat” should be loaded from the hard disk, because this data is used in the following chapters of the manual.



Open new data file

Click on the Open symbol in the Tool bar. Choose the file data.dat, which has the demo path (...\\diadem\\demo\\dat). Confirm your selection with “OK”.

The newly opened DIAdem® data channels now appear in the overview. They are thus available in the Data area to be used by other DIAdem® devices.

Note: The last path [from which a data file was loaded] is used as a new user path in DIAdem®-DATA for the current session.

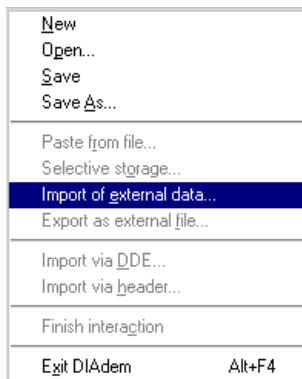

Apart from DIAdem® data files, other external data can be imported using the File menu. The user can extend the list of available file formats by including appropriate GPI file import/export filters. Information about these filters can be requested in the “Options – External file type info” menu. You will find more details about the GfS Programming Interface GPI in the program help.

DIAdem VIEW: Viewing, Measuring & Editing Data

DIAdem[®] VIEW allows you to view, measure and edit your data. Data may be displayed as graphs defined by an X and Y channel of the data area in various axis systems. Various cursors are used for inspecting the graphs, using which you can zoom, scroll or carry out measurements.

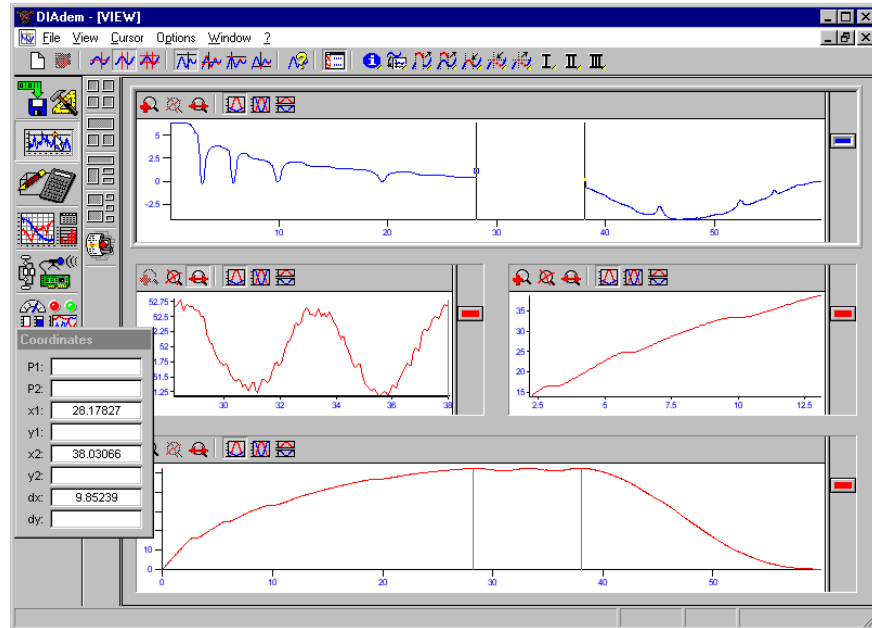
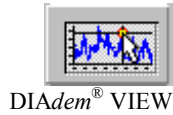

DIAdem[®] VIEW Module bar

The DIAdem[®] VIEW Module bar determines the way in which the screen is divided up. You will find various possibilities for standard and customized screen partitions in the corresponding Action bars.

After double-clicking on an axis system, you can coordinate the data channels to be displayed, thereby defining the graphs. A legend can be displayed beside each axis system showing the data channel name, the unit, the cursor coordinates and any expressions at will. Use the graph symbol between the axis system and the legend to copy a graph into another axis system by grabbing it with the mouse and moving it into the target axis (drag and drop).



Part of the DIAdem[®] VIEW Tool bar

In the Tool bar you will find various types of graphics cursors used to inspect graphs, as well as various measurement cursors with which you can find characteristic graph points. Other useful features are the symbol for turning the coordinate display off and on and the feature Delete all graphs.



Command icons assigned Autosequences

In addition to the standard functions, other functions can be assigned to the command icons, which are marked with a yellow triangle, as Autosequences (requires the Autosequence option).



Axis-specific Tool bar

Each DIAdem[®] VIEW axis system has its own axis-specific Tool bar which you can use to enlarge a selected region of the graph (zoom and scroll) and, in the case of several axes with different value ranges, change the scaling of the Y-axis.

Viewing Data as Graphs



Load data in DIAdem®-DATA

The data file "Calc3.dat" has been used for the screen display on the first page of the chapter. If you have modified the example data set in the DIAdem®-DATA device, which is loaded automatically, load the data file "Data.dat" from the user data path (...\\diadem\\demo\\dat).

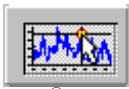

DIAdem® VIEW

To work with DIAdem® VIEW, click on the corresponding button in the Device bar.

The DIAdem® VIEW Working area contains several axis systems in which data from the Data area may be viewed as graphs. Note that the active axis system is displayed with a highlighted frame while the axis of the passive windows do not have a highlighted frame. The cursor can be moved with the mouse through the active axis system, whereas it simply "follows along" in the passive system when the value range is the same.

Graph Definitions: Entering and Deleting Graphs in an Axis System

To enter a graph into an axis system, coordinate any set of X and Y channels in the graph definition. Of course several graphs may be entered into an axis system.



Double-clicking on an axis system opens the graph definition

Double-click (click twice in rapid succession) on the upper axis system. The Graph definition dialog box appears.

The Graph definition gives you an overview of previously defined graphs in the active axis system. In our example this line is still blank.



Entering new graph(s)

To specify the data channels you wish to display, click on the "New entry..." button. Choose the data channel "Time" as the X channel and "Speed" as the Y channel. Exit the sub-dialog box with "OK".

Note: Two or more graphs can be defined at once for the same basis. Use the X channel, and mark the two Y channels with the right mouse key. After "OK", two graphs are entered in the list.



Deleting graph

This new graph entry now appears in the overview in the main dialog box. If you wish to, you can later delete the graph from the axis system with Delete.

The Graph definition dialog box

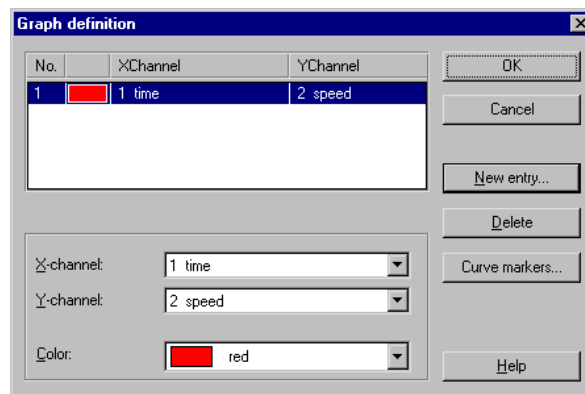

Graph points can be emphasized with colored symbols, as it will be shown in DIAdem®-GRAPH, using the "Graph markers".



Graph symbol

After you exit the Graph definition with OK, the graph is entered into the active axis system. At the same time, the corresponding graph symbol appears beside the axis system, a small rectangle in the corresponding graph color, red.

Using the Graphics Cursor in DIAdem View

A number of graphics cursors are available to move or measure one or more graphs. You can choose from a crosshair, frame or band cursor. Use the mouse to access the cursor (in the active axis system only). The graphics cursor follows along passively in the other axis systems to the extent the range of values agree.



Crosshair cursor

The crosshair cursor, used for example to measure graph coordinates

The crosshair cursor consists of horizontal and vertical cursor lines which can be moved independently. The point of intersection defines the X and Y coordinates, which appear in the Status line as X_1 , and Y_1 .

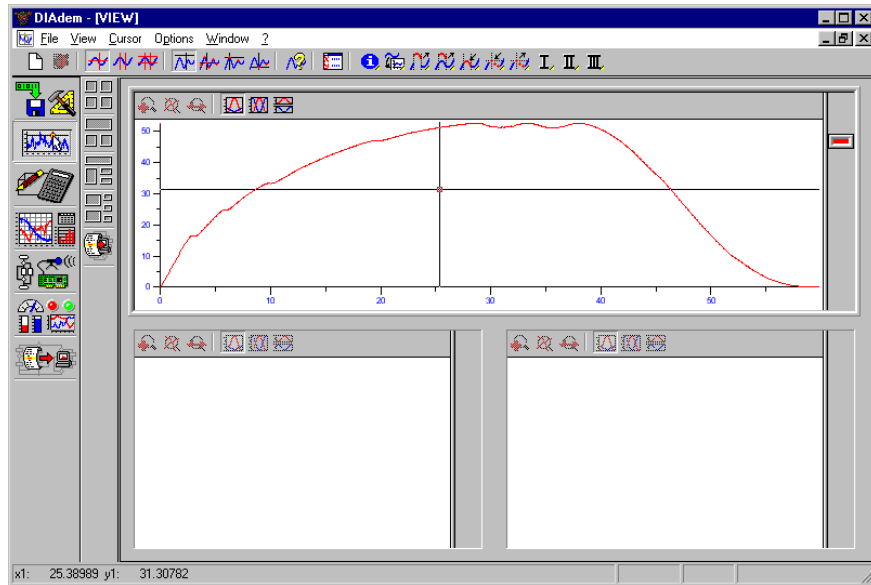

Positioning the crosshair cursor

Whenever you press the left mouse button and hold it down in the active axis system, a small cross appears. When you move the mouse, the crosshair cursor “snaps” to the mouse cursor coordinates and follows any further mouse movements.

Note: If you move the mouse over one of the crosshairs, the graphics cursor changes into a horizontal ($\sqrt{\quad}$) or vertical arrow (\cdot). At this point you can hold the left mouse button down and move the cursor line horizontally or vertically.

Using the Cursor Position to Measure a Graph

The intersection point of the crosshair cursor is surrounded by a small square. This square is used to follow the path of the graph. The other cursor types also use this “measuring square”.

The intersection point of the crosshair cursor is surrounded by a small square. This square is used to follow the path of the graph. If you choose another of the cursor types, the “measuring square” will remain at an intersection point.



Free Cursor

By default, the graphics cursor is set to move freely, allowing the cursor to be moved anywhere in the active axis system. If you select other positioning settings, certain graph points will be sampled and selectively displayed in the Status line.



Delete all data

The whole data area is emptied with the “empty page” symbol in the tool bar.

In the following, the example file “Data.dat” should be loaded from the hard disk, because this data is used in the following chapters of the manual.

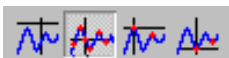

Graphics cursor

Choose the graphics cursor in the command line. When you move the mouse, the crosshair stays on the graph and moves from point to point along it. In this manner you can display coordinates for any point along the graph.

Note: The *Maxima-cursor* and *Minima-cursor* can be switched on. When on these settings, the graphics cursor moves from one extreme value to the next.

Graph Legend: Displaying the Axis-Oriented Display

The legend can be displayed next to any axis system.

+||→
Displaying legends

Move the mouse cursor over the right border of the axis system. When the table cursor appears with two vertical lines, hold the left mouse button down. Then move the legend off to the left.

The name of the Y data channel, the unit and, with the corresponding graphics cursor, the X and Y coordinates are shown in the legend. It is possible to add additional displays and define their arrangement.

Double click on the legend and the parameters dialog box appears. Click on "Type" in the 5th line and select "Free Text".

The form of the coordinate display can be changed.

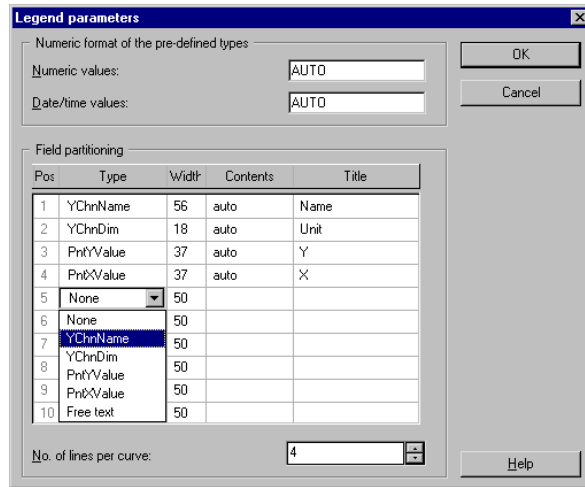

OK

Close the dialog with "OK".

Now, the channel name, the channel unit, the maximum value are displayed in the legend, as well as the graph coordinates of the graphics cursor position, which are updated continuously.

Legend with graph data as well as the maximum value as the result of a formula

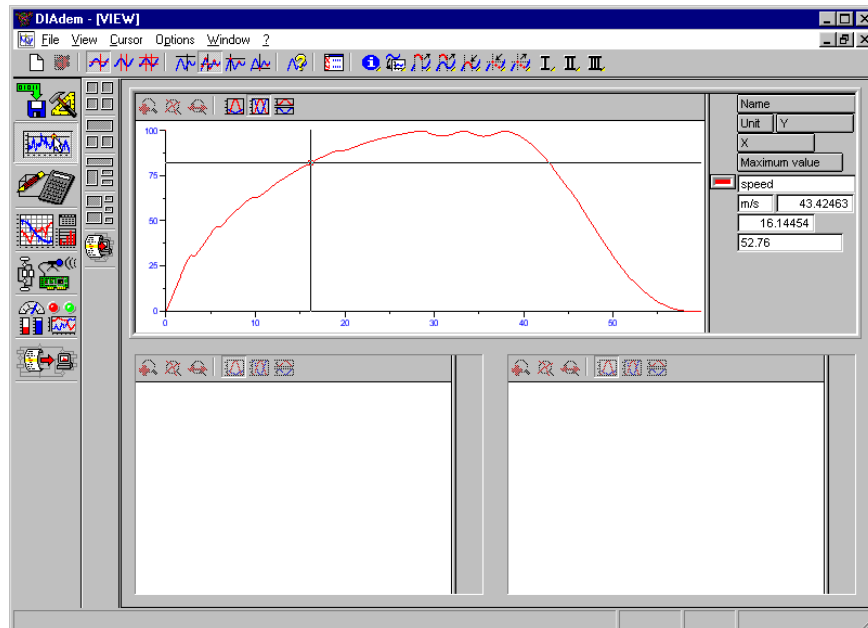

Global Coordinate Display: Displaying Cursor Coordinates in Overview Format

The current coordinates of the graphics cursor, represented in the unit of measure of the active axis system, are shown in the status line. You can also choose to have an overview of the coordinate display.



Coordinate display

First activate the frame cursor. Then turn on the coordinate display in the Tool bar.

A window appears with the current cursor coordinates of the active axis system. This window may be positioned anywhere on the screen. For the frame cursor, the X and Y coordinates and the distances for horizontal and vertical cursor lines (dx, dy) are displayed.

Coordinate display with frame cursor coordinates

Coordinates	
P1:	277
P2:	
x1:	16.14454
y1:	43.42463
x2:	21.93552
y2:	47.88644
dx:	5.79098
dy:	4.46181

Axis-local Scaling: Various Graphs in one Axis System for Clarity

If graphs whose value ranges are different are to be compared with one another in an axis system, the depiction can be improved by choosing a different scaling mode. The scaling mode is set separately for every axis system.



Graph definition

Define one more graph in the upper axis system. Call the graph definition and set a new graph with the X-channel "Time," the Y-channel "Rotational Speed" and the color "Green." Click "OK" twice and return to the working area.



Axis-local scaling, here: 1 System [%]

Since the absolute values of the rotational speeds are 100 times higher than the absolute speeds, the speed curve is merely displayed as a colored line on the abscissa. In this case, it is advisable, to switch the scaling mode for that axis system to "1 System [%]." The labeling of the ordinate will now be done referred to the entire Y-value range as a percentage.

In a case of several graphs with different value ranges, a scaling that is more favorable for the depiction should be chosen

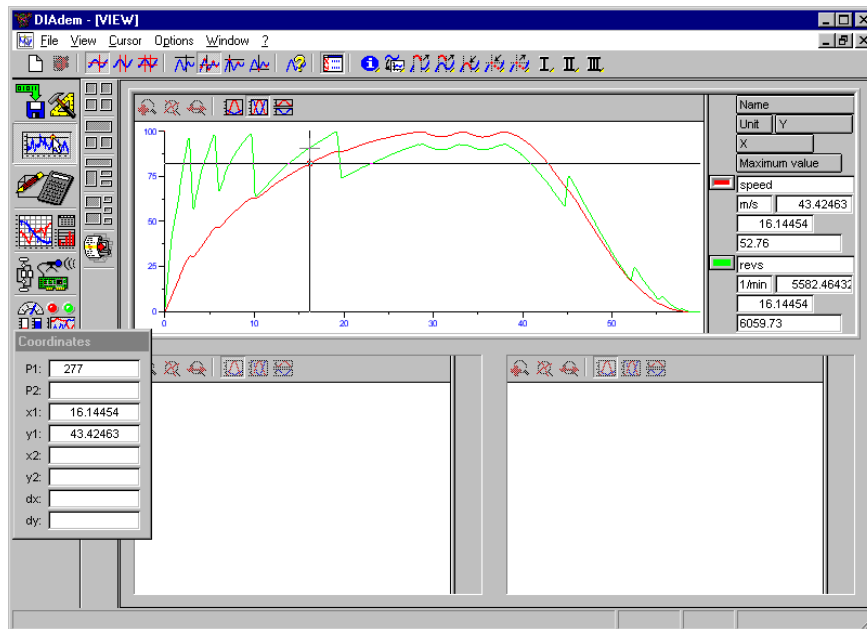

Note: The depiction can be done in separate sub-axis systems with the scaling “n Systems” [physical].

Define main graph To carry out measurements on graphs, one of the two should be defined as the main graph. This definition is made in the context menu of the corresponding graph symbol.

Open the context menu with a click of the right mouse button on the red graph symbol and select “Set main graph.” When you call this context menu again, you can see that the main graph has been set.

In the case of several graphs in an axis system, the main graph is defined via the context menu of the graph icon

Now, if you move the crosshair cursor, it remains fixed on the red graph. Another crosshair is displayed on the green graph. The point coordinates of the main graph are displayed in the legend, as specified.

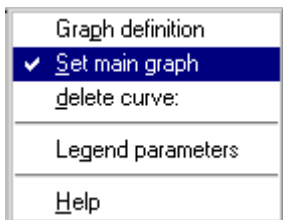

As mentioned above, if the value range is the same, the cursors in the passive axis systems follow along. If you have selected the “Free Cursor,” the crosshairs in the passive windows orient themselves according to the graph coordinates. If you have activated another cursor, e.g. “Maxima-cursor,” the crosshair will be oriented in the passive windows according to the point number; the relevant coordinates can be read in the legends.

Depending on where you click in DIAdem®-VIEW [with the right mouse button] the context menu is displayed with other functions. For example, the image mode toggle may be displayed. Note that the image mode determines whether a SHELL is displayed or suppressed.

How to Copy or Delete a Graph

Any graph that has previously been defined can be copied into another axis system using the drag-and-drop procedure and the corresponding graph symbol.

 Copying a graph with the graph symbol activated.

Drag the red graph symbol by pressing on the left mouse button. With the left button still held down, move the graph symbol into the lower left axis system and release the left mouse button.

Deleting a graph

A copy of the graph and the corresponding red graph symbol now appear in the desired axis system.

You can also delete a graph from the axis system using the graph symbol. Click on the green graph symbol; it darkens. Then press the <DELETE> key. Alternatively, deletion can also be done from the context menu of the graph icon

Deleting or copying multiple graphs

Multiple graphs can be deleted from or copied to the same axis system. Select the corresponding graph symbols with the mouse and the <CTRL> key.

Using Zoom, Scrolling and Screen Partition

Zoom: Enlarging Graph Segments

If you want to inspect a given region of a graph with increased precision, you can use the DIAdem® VIEW zoom feature to portray selected portions of the graph in enlarged format. The zoom feature can be executed only with a band or frame cursor.

The band cursor consists of two parallel vertical cursor lines which define a segment of width delta X (designated dx in the Status line). The X position of the cursor line that is set first is used for the X_1 coordinate, to which is also assigned the small square, the so-called “Hot Spot.” The X-position of the cursor crosshair that is set last is used for the X_2 -coordinate. The same applies correspondingly for the Y_1 - and Y_2 -coordinates of the frame cursor.

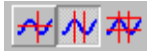

Activating the band cursor

Copy the graph from the upper axis system into the axis system on the lower left. Then activate the band cursor in the Tool bar.

Move the band cursor by clicking between the two cursor lines and moving the mouse right or left while the left mouse button is held down. You can define the width of the band cursor by positioning the cursor crosshairs.



Widening the band cursor range

Move both band cursor lines with the left mouse button held down until the region of the graph you wish to inspect lies between the two cursor lines.



Zoom in

Now turn the zoom on for this axis.

The graph segment delineated by the band cursor now fills up the entire axis system.

A graph in maximized view and the band cursor section in zoomed view

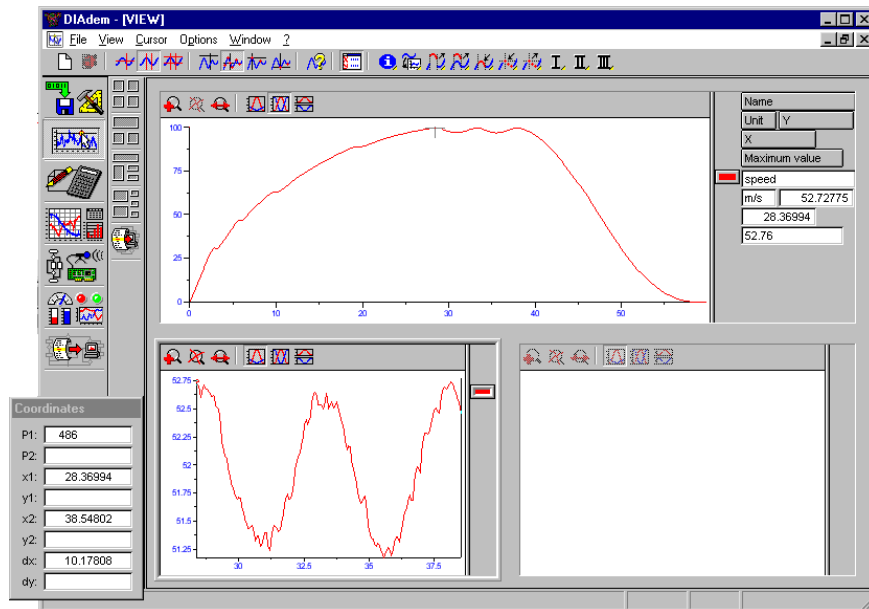

If several graphs are defined in the same axis system, graph segments [that are contained within the band cursor] will be equally magnified. Note that you can zoom in on segments recursively, thus inspecting smaller and smaller graph segments.



Zoom off

After you turn off the zoom, the original graph is displayed, no matter how many times you have zoomed in.



Frame cursor

The frame cursor is used in the same manner as the band cursor. In addition to horizontal lines, it provides vertical definition.

Scrolling Through Graph Segments

While the zoom feature allows you to examine individual enlarged graph segments statically, the scroll feature allows you to move along the enlarged graph. It is as if the graph were scrolled along under a magnifying glass.



Turning on scrolling

Using the graph symbol, copy the red graph into the lower right-hand axis system. If no band cursor is active, choose one. Widen the segment width as needed. Then activate scrolling in the axis-specific Tool bar.

Now you can let the speed graph move through by holding down the left mouse button while moving the mouse cursor horizontally.

Since the graphics cursor is always visible in axis systems with graphs, the graphics cursor in passive systems follows along correspondingly as long as the X value regions are equal. If zooming is active in an axis system, the graph section that has been set there remains unchanged!

Scrolling through a segment
in the lower right-hand axis system

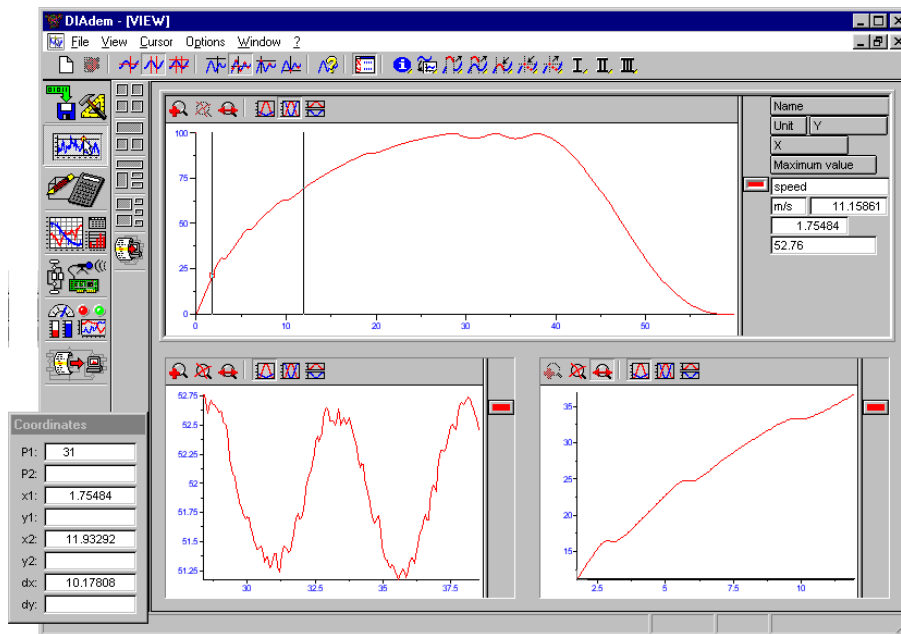

Apart from directly moving the graph with the mouse, the so-called scrollbar can also be used for moving. For this purpose, the horizontal scrollbar should be activated in the context menu. Now, the graph can also be moved by moving the scrollbar. If you are working with a frame cursor, it is sensible to insert the vertical scrollbar.



Scrolling off

Scrolling can be de-activated at any time. In contrast to zoom, the last segment viewed stays in place; it is “frozen.” Enlargement can be undone with the Zoom off symbol, since zooming also occurs when scrolling is turned on.

When you activate another axis system, zooming and scrolling retain their settings in the old axis system. This means in terms of the example above that you can place the band cursor in the upper axis system over the speed graph and view the graph enlarged in the lower right-hand axis system.

Screen Partition: Re-arranging Axis Systems

Depending on the task, three axis systems may be too few - or too many, in order to view and compare graph sections of one or more graphs. Modules with both regular and irregular screen partitions are available for this purpose. For the following example, the number of axis systems is to be reduced to two.

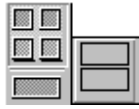

Two systems of the same size in a vertical row

Click to the function group of the regular screen partitions with the four squares. Select the two axis systems that are arranged underneath each other.

The defined graphs are retained in all axis systems.

Note that since graphs had been previously entered in more axis systems (than are selected now), the “extra” graph definition is automatically lost. Even if three axis systems were to be selected in a subsequent step, the third axis system remains without graph entries.



Delete all graphs

For further graphical analyses of the same or other data, all the defined graphs in all the axis systems can be deleted in one go with the icon “Delete all graphs” in the toolbar of commands.



Autosequences for graph manipulation and transformation

Special functions for graph manipulation and for documentation as a diagram are realized as Autosequences and require the Autosequence option.



Electrostatic Discharge (ESD), Handling Notice 8-1
ReadMe Files and the Install CD-ROM 8-1
Driver Support..... 8-2
Connection Problems..... 8-2
32-Bit WaveView Issues..... 8-2
Windows NT V3.51..... 8-3
Windows 95/98/2000 Problems..... 8-3
Resource Settings..... 8-3
Parallel Port Setup..... 8-3
Customer Assistance 8-5

Electrostatic Discharge (ESD), Handling Notice



The discharge of static electricity can damage some electronic components. Semiconductor devices are especially susceptible to ESD damage. You should always handle components carefully, and you should never touch connector pins or circuit components unless you are following ESD guidelines in an appropriate ESD-controlled area. Such guidelines include the use of properly-grounded mats and wrist straps, ESD bags and cartons, and related procedures.

ReadMe Files and the Install CD-ROM

The Install CD-ROM includes ReadMe Files. These files often contain late-breaking information that may not appear in the user documentation. During installation you should review the ReadMe files when prompted to by the program.

The Install CD-ROM also includes:

- WaveBook Windows NT driver
- WaveBook Windows 95/98/2000 driver
- **DaqX.DLL** (32-bit API) for WaveBook
- Microsoft C/C++ API support
- Microsoft VB API support
- Borland Delphi API support
- Daq* Configuration Control Panel Applet
- Program User's Manual (PDF)

Upon installation, the user needs to run the *Daq* Configuration* Control Panel applet. The applet is used to configure WavePort for an appropriate LPT port. This must be performed in order for the application to access WavePort through the Windows NT or Windows 95/98/2000 driver.

Note: From the perspective of software, the WavePort devices appear as follows:

- **WavePort/PE8** - a WaveBook/516 connected to one WBK14 module.
- **WavePort/PE16** - a WaveBook/516 connected to two WBK14 modules.
- **WavePort/V8** - a WaveBook/516.
- **WavePort/V16** - a WaveBook/516 connected to a WBK10 module.
- **WavePort/V24** - a WaveBook/516 connected to two WBK10 modules.

Driver Support

The daqX API can be used with WaveBook [WavePort], DaqBook, DaqBoard, Daq PC Card and TempBook product lines. All daqX functions share the **daq** prefix.

The API support examples can be found in the installed directory `\LANGS\WAVEBOOK`.

Connection Problems

If communications cannot be established with the WavePort or, if trying to connect causes the system to hang or crash, try the following:

- Verify that the MODULE POWER switch is set to ON and that the MODULES ON indicator is lit.
- Check to make sure that the Notebook PC communication cable is properly connected to the WavePort's DB25 connector labeled "TO COMPUTER PARALLEL PORT."
- Check that the desired LPT port is properly configured and the base address and interrupt are recognized by the operating system.
- Check the BIOS settings for the LPT port. Make sure that the BIOS LPT protocol settings are compatible with the settings selected for the LPT port. "Compatibility mode" is recommended.
- Run the *Daq Configuration* applet from the Windows Control Panel. Make sure the device is configured to the appropriate LPT port with the appropriate protocol. Run the device test and if it fails try other protocols for the device. Be sure to click on **<Apply>** to apply the settings, before re-running the test.
- **Windows NT:** Make sure that the driver has been loaded. The installation will configure the operating system to automatically load the driver at boot-up. However, if there is a problem communicating with the device, the driver can be loaded manually by using the following start sequence from a DOS shell:
NET START WAVEBK. To unload the driver manually, use the following sequence:
NET STOP WAVEBK.

32-Bit WaveView Issues

- The 32-bit version of WaveView uses a default scheme whereby buffer allocation is dynamic depending on the amount of physical memory on the computer. An advanced feature is available in this release to let the user have more control of the buffer allocation. Generally, better performance will be obtained by increasing the amount of RAM. This allows fewer swaps of VM (virtual memory) to the drive thus allowing the possibility of greater performance. However, VM management during acquisition configuration for large acquisitions may cause WaveView to take a significant amount of time to configure the acquisition.
- Acquisition parameters can no longer be changed during an active acquisition. The 16-bit version of WaveView allowed the changing of configuration parameters during an acquisition.
- Scope scale changes do not become effective until the focus changes. This is best accomplished by hitting **<Enter>**.
- International settings are supported, but some text boxes may not completely show the comma when it is used as the decimal place holder.
- The *Scope Mode's* print resolution is determined by the host computer's video driver. Some graphics drivers may require adjustment of the resolution and/or color palette for proper print operation. For some printers, better output is attained by changing the printer's dithering setting to "None".
- Text boxes for the filter settings may not display the proper setting if the number entered must be rounded to the nearest filter setting. This is a problem only with the number displayed and does not affect the actual filter setting passed down to the driver.
- Conversion to Snap Master format from the menu option is not supported. Snap Master format conversion does work properly when done as part of a direct-to-disk acquisition.

Windows NT V3.51

For Windows NT applications, it is important to note that WaveView can only be run on Windows NT 4.0, or higher. Windows NT 3.51 is not fully supported.

Windows 95/98/2000 Problems

This section only applies to Windows 95/98/2000 installations.

Resource Settings

If the WavePort fails to communicate or has problems transferring data, there may be a resource conflict with other devices within the system. Take the following steps if this appears to be the case.

Parallel Port Setup

If WavePort fails to communicate or has problems transferring data there may be a problem with the way the parallel port is configured. If this appears to be the case take the following steps:

- 1 Ensure that any hardware settings on the parallel port are configured properly. If unsure of proper configuration, refer to the parallel port manufacturer's documentation. If this fails to solve the problem, proceed to the next step until the problem is resolved.
- 2 Click the Windows desktop *Start* button; select the *Settings* menu item; then, select the *Control Panel* menu item.
- 3 Double-click the *System* icon.
- 4 Click the *Device Manager* tab.
- 5 If the small box to the far left of the "Ports (COM & LPT)" entry contains a "+", click once on the "+" to show all your communication and line printer ports.
- 6 In the Configuration utility, click once to highlight the line containing the LPT port you chose to use with WavePort.
- 7 Click the *Properties* button.
- 8 The *Device Status* section should contain the message "This device is working properly." If the message is not present, either the wrong I/O address is selected, or the hardware is missing or broken.
- 9 Click the *Resources* tab.
- 10 The *Resource Settings* section should contain entries for "Input/Output Range" and "Interrupt Request" with "Settings" from the table below that correspond to the LPT port chosen for WavePort.

Note: A "Direct Memory Access" entry may also exist for EPP or ECP printer ports.

Printer Port	Input/Output Range	Interrupt Request
LPT1	0378-037B (or 037F)	7
LPT2	0278-027B (or 027F)	5
LPT3	03BC-03BF	7 (shares with LPT1)

If the settings do not correspond to those in the above table, or if there is no "Interrupt Request" entry, follow these steps 10a through 10b before moving on to step 11.

10a. Click on the check mark in the small box to the left of "Use automatic settings".

10b. Click on the now active drop-down combo-box to the right of "Setting based on:"

10c. Click on different "Basic configuration" choices (use the up-down slide bar to the right if needed) until the resource settings match those of your printer port in the table above.

11. The "Conflicting device list" section should contain the message "No conflicts." If this is not the case,, and a DMA conflict is described, repeat Steps 10a - 10c *but change only the DMA setting*.
12. If one or more conflicts are described in the "Conflicting device list" section, you must find the conflicting device(s) and change the conflicting resource(s) by following these steps:
 - 12a. Take note of all conflicts, then click the *OK* button.
 - 12b. If a window appears titled "Creating a Forced Configuration", click *Yes* to continue.
 - 12c. Open the conflicting device type by clicking on the "+" in the small box to its left, if necessary.
 - 12d. The conflicting device's icon should be marked with an exclamation point in a yellow circle. Click once on the device to highlight it; then click the *Properties* button.
 - 12e. Click the *Resources* tab.
 - 12f. Perform Steps 10a - 10c to resolve the resource conflict.
 - 12g. Repeat Step 11 for each additional existing resource conflict.
13. If one or more resource conflicts remain, the conflicting device(s) must either be removed or kept absolutely dormant for proper operation. Click the *OK* button to close the device properties window and return to the "System Properties" window. If a window appears titled "Creating a Forced Configuration", click the *Yes* button to continue. To remove a device, perform the following steps:
 - 13a. If necessary, open the device type by clicking on the "+" in the small box to its left.
 - 13b. Click once on the device to highlight it, then click the *Remove* button.
 - 13c. Click the *OK* button to confirm the device's removal.
14. Click the *Close* button to close the "System Properties" window. Close the "Control Panel" window and any other tasks running; then shut down Windows 95/98.
15. If any hardware was removed in Step 13 or if any hardware reconfigured in Step 12 requires manual reconfiguring, power off the computer and remove or reconfigure the hardware before rebooting. Otherwise, simply reboot the computer.
16. Run the Configuration utility and test WavePort's communication. If problems persist and no resource conflicts exist, perform the following steps:
 - 16a. Check for loose cable connections and verify the MODULE POWER indicator is ON.
 - 16b. Verify that the computer's printer port and data cable work with a printer or other device.
 - 16c. Verify there are no installed devices that Windows 95/98/2000 does not recognize but whose resources might conflict with the WavePort.
 - 16d. Verify that WavePort works on another PC (from a different manufacture if possible).

Customer Assistance

To report problems and receive support, call or e-mail the manufacturer's Applications department or visit the web site.

When you contact us, please provide the following information so support personnel can help you most efficiently:

- Hardware model numbers and software version numbers.
- Operating system, type of computer, and device information in the Windows control panel, such as interrupts and address settings for our hardware and others.
- Results of tests, such as the Daq* Configuration control panel.
- Hardware setup and software configuration.
- Information on input signals, including voltage ranges, signal impedance ranges, noise content, and common mode voltages.

All equipment returned to the manufacturer must have an RMA (Return Material Authorization) number. You can obtain an RMA number by calling the Customer Service or Applications departments. When returning the equipment, use the original shipping container (or equivalent) to prevent damage. Put the RMA number on your shipping label to ensure that your shipment will be handled properly. After receiving your equipment, we will fax a confirmation form that summarizes the charges (if applicable) and expected return date.

IOtech can be reached by one of the following means:

Phone: **(440) 439-4091**

Fax: **(440) 439-4093**

E-mail (Product Information/Sales): sales@iotech.com

E-mail (Technical Support): productsupport@iotech.com

Internet: <http://www.iotech.com>

Mail: **IOtech, Inc. • 25971 Cannon Road • Cleveland, Ohio 44146-1833**



Notes

- General Maintenance.....9-1*
- Fan Filter: Cleaning and Replacement 9-2*
- What Type of Environment is WavePort Intended for?9-3*
- How Should WavePort be Transported? 9-3*
- Should I Calibrate the WavePort?9-4*
- How do I get Replacement Parts or Service?9-4*

WARNING



The Notebook Power receptacle is “LIVE” whenever WavePort is plugged into a live AC power source. The Module Power Switch can not be used to turn this receptacle “Off.”

WavePort contains no user serviceable components. Do not remove WavePort’s cover plate. Lethal voltages are present which could cause serious injury or death.

General Maintenance

WavePort should be treated much like other high-tech equipment. In general:

- Keep WavePort clear of harsh chemicals and abrasive elements.
- Avoid exposing the unit to extreme heat, such as setting next to a boiler or furnace.
- Avoid extreme shock and vibration.
- Avoid subjecting the air intake and exhaust vents to liquids and extremely fine air particulate, such as silica dust.

A “common-sense” approach to handling WavePort will go a long way in regard to protecting your unit from inadvertent damage.

You can clean WavePort’s case and cover plate with Isopropyl Alcohol (Rubbing Alcohol) and lint-free rags. These items are typically available at general stores.

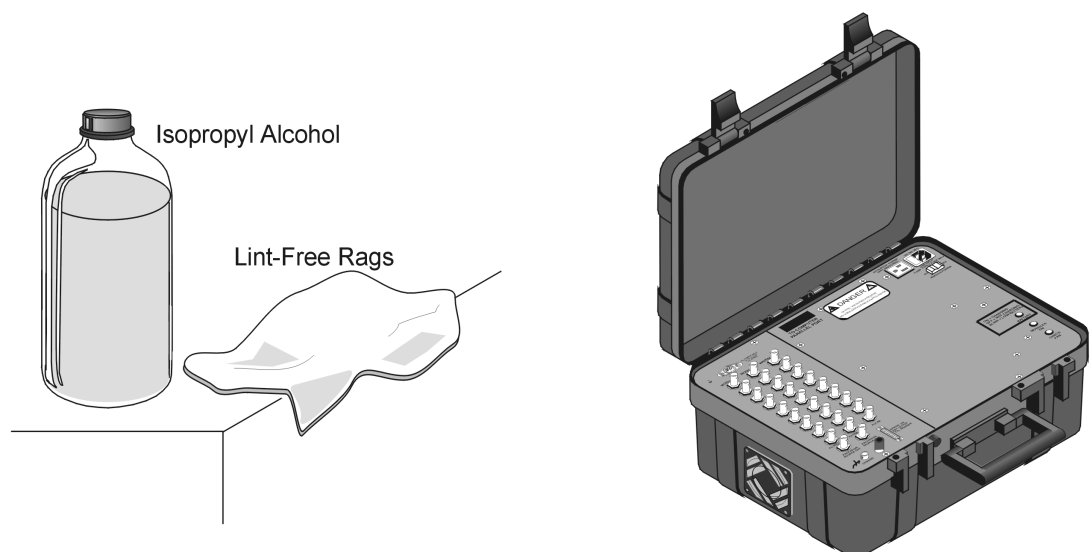

You can use rubbing alcohol and lint-free rags to clean WavePort’s case and cover plate.

Fan Filter: Cleaning and Replacement

To Clean the Filter Media:

1. Turn WavePort “OFF” and unplug the unit.
2. Remove the four screws from the Metal Guard.
3. Remove the Metal Guard and the Guard-Media-Retainer (the later is a snap-together assembly).
4. Using mild detergent, clean the Media while it is still encased between the Guard and the Retainer.
5. Rinse under running water; then air-dry.
6. Secure Guard-Media-Retainer and Metal Guard to WavePort using the four Screws that were removed in step 2.

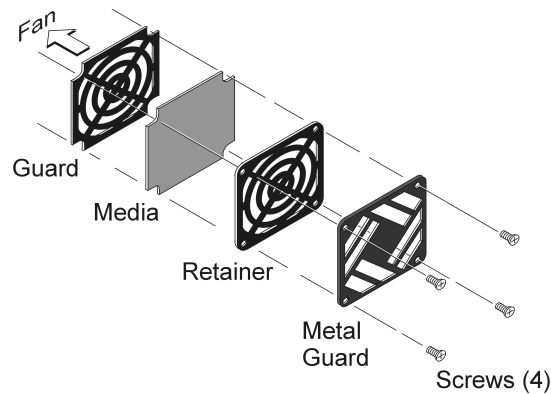

Fan Filter Media with Retainer and Guards

To Replace the Filter Media:

1. Perform steps 1 through 3 from above.
2. Pry the Guard (plastic) from the Retainer.
3. Remove the old Media.
4. Clean the Guard and Retainer, if needed.
5. Position new filter Media between Guard and Retainer.
6. Snap the Guard, Media, and Retainer together.
7. Secure Guard-Media-Retainer and Metal Guard to WavePort using the four Screws.

What Type of Environment is WavePort Intended for?



WavePort was designed to operate within -20° to +60°C (-4° to 140°F) and a relative humidity of up to 95%RH, non-condensing. The unit can be stored at temperatures in the range of -40° to +70°C (-40° to 158°F). These parameters do not apply to the user-supplied Notebook PC, and you must refer to your Notebook's documentation for environmental factors regarding that device.

When closed, WavePort's case will protect the Notebook and the top of WavePort's cover plate from snow, rain, dust, and other elements.



Prior to transporting the system in inclement weather, turn the device "OFF" and place the unit in a plastic bag. This simple action will prohibit water and wind-blown debris from entering WavePort through its fan intake and air vents.

How Should WavePort be Transported?



WavePort's own case is not intended to provide complete protection from shock and vibrations that the unit can experience during shipments.

This section pertains to transporting WavePort by road vehicles, trains, ships, and planes.

WavePort has been tested for shock and vibration. In regard to transportation the device falls under MIL-STD-810E, Category 10 Transportation Standards. In general, this means that WavePort should receive additional packaging; and that it should be secured while in transit.

As WavePort contains an internal power supply, circuit boards, and related high-tech components it should be transported with the following steps taken:

- Module Power Switch positioned to "OFF."
- All cabling disconnected.
- Notebook PC removed from the unit.
- No loose items present in the unit.
- Cover closed and latched (padlock optional).
- WavePort placed in a plastic bag to keep packing materials and debris from entering the vents
- Unit placed in heavy cardboard box, with packing material to absorb shock.
- Shipping box labeled "**FRAGILE – SENSITIVE EQUIPMENT**," or other words to that effect.
- Instruction provided to the shipping agent to "secure the package as to minimize shock and vibration while en route."

Though WavePort can be transported by plane, WavePort's mechanical and electronic aspects can cause concern, especially if there is an attempt to take the unit onboard as "carry-on luggage." The level of concern is likely to vary from airport to airport; and International flights can complicate the matter. To reduce the possibility of delays, always notify airport security of the nature of the device before scheduling the flight.



It is a good idea to remove the Notebook PC from WavePort prior to shipping the unit. If you want to transport the unit with the Notebook installed, it is highly recommended that you lock the case shut with a small padlock. WavePort's latches contain holes for this purpose.

Should I Calibrate the WavePort?

No.

WavePort should be calibrated periodically, but only by the factory, or a factory approved service representative.

It is recommended that WavePort be calibrated yearly; however, calibration periods often vary, depending on your application.

If you suspect that the unit needs calibrated you should obtain channel readings from a source with a known value; then, if the readings indicate a need for calibration, contact the factory.

IOtech can be reached by one of the means provided in the following section.

How do I get Replacement Parts or Service?

Aside from external components, WavePort contains no user serviceable parts. If you suspect an internal problem you should promptly call your service representative. Be aware that you should never remove WavePort's cover plate.

The following parts can be replaced by the user:

- Fan Filter: Media, Guards (1 plastic, 1 metal) and Retainer
- AC Main-Line Power Fuse (2 Amp, Type T, 250 V)
- CA-35-2 DB25M-to-DB25M Cable (connects WavePort to Notebook PC)
- CA-1, IEC Power Cable
- Adhesive Foam Seal, ST-5-6 Tape (for WavePort's upper-lid, padding for Notebook PC)
- Dual-Lock Fastener with Adhesive (Velcro® type strips for holding Notebook PC to WavePort's Cover Plate)
- 1026-0601, Installation CD-ROM (Includes WaveBook and DIAdem Software)
- HA-192, Accessories Pouch – for holding cables and other small items

Accessories

The following accessories can be ordered for use with WavePort. Parts preceded by "CA" are cables.

- WBK20A PC-Card (Option for connecting WavePort to Notebook PCMCIA slot). Includes PC Card and mating DB25 connector cable, see *Appendix B* for details.)
- CA-198, 5-pin DIN to Vehicle Cigarette Lighter (length: 10 ft., 3.048 m)
- CA-178, DB25 to external clock BNC
- CA-150-1, Single Male BNC to Male BNC, CE Compliant cable
- CA-150-8, Eight Male BNC to Male BNC, CE Compliant cables

WARNING



The Notebook Power receptacle is “LIVE” whenever WavePort is plugged into a live AC power source. The Module Power Switch can not be used to turn this receptacle “Off.”

WavePort contains no user serviceable components. Do not remove WavePort’s cover plate. Lethal voltages are present which could cause serious injury or death.

Remember that WavePort contains no user serviceable components.

Contact your service representative in regard to obtaining service.

You can reach IOtech by one of the following means:

Phone: **(440) 439-4091**

Fax: **(440) 439-4093**

E-mail (Product Information/Sales): sales@iotech.com

E-mail (Technical Support): productsupport@iotech.com

Internet: <http://www.iotech.com>

Mail: **IOtech, Inc. • 25971 Cannon Road • Cleveland, Ohio 44146-1833**



WavePort/PE Specifications 10-1

WavePort/V Specifications 10-4

Note: Specifications are subject to change without notice.

WavePort/PE Specifications

Analog Specifications All analog specifications are one year, 18-28°C unless otherwise noted.

Voltage Inputs, Channels 1-8 (WaveBook Module)

Channels: 8 differential

Input Connector: BNC, center conductor is Channel Hi, outer conductor is Channel Low

Resolution: 16-bits

Input Voltage Ranges (software programmable via sequencer):

Voltage Range	Accuracy (Note 2) One Year, 18-28°C		Input Noise (LSB rms) 10Hz-500KHz (typical)
	± % reading	± % range	
0 to +10V	.012%	.006%	3
0 to +4V	.012%	.006%	3
0 to +2V	.012%	.008%	3
-10 to +10V	.012%	.006%	2
-5 to +5V	.012%	.006%	2
-2 to +2V	.012%	.006%	2
-1 to +1V	.018%	.008%	3
Notes: 1. Specifications assume differential input scan, unfiltered. 2. Accuracy specification is exclusive of noise.			

Voltage Specifications (Channels 1-8) one year, 18-28°C unless otherwise noted

Differential Nonlinearity: ± 3 LSB max

Total Harmonic Distortion (10Hz-20KHz): -84dB typical

Signal to Noise and Distortion (SINAD, 10Hz-20KHz): -74dB typical

Temperature Coefficient: ± (.002% + 0.3 LSB)/°C typical (-10 to 18°C and 28 to +55°C)

Input Resistance: 5MΩ (single ended); 10MΩ (differential), in parallel with 30pF

Bias Current: <400 nA (0 to 35°C)

Common Mode Rejection: >70dB minimum; >80dB typical; dc-20KHz

Input Bandwidth: dc to 500KHz

Hostile Channel-to-channel Crosstalk (5Vrms input signal, dc-100KHz): -90dB typical

Over-Voltage Protection: ±35 V relative to analog common

PGA Filter: 20KHz low pass, Butterworth, 5-pole filter

Accelerometer Inputs:

Module 1, Channels 1-1 through 1-8; Module 2, Channels 2-1 through 2-8 (PE16 version only)

Accelerometer Channels: 8 (for PE8); 16 (for PE16)
Inputs: BNC, Center conductor is Hi, shell is common ground for all channels
Input Impedance: 150K Ohm
Input Ranges: 5V, 2.5V, 1V, 500mV, 250mV, 100mV, 50mV, and 25mV peak
Accuracy: ± 0.5 dB at the passband center
Coupling: AC only
Frequency Resolution: 1% of cutoff frequency of each filter range
Low pass Filter type: 8-pole Butterworth, software selectable, with 2-pole antialiasing prefilter
Low-Pass Filter Frequency Cutoff Range: 100KHz, 75KHz, 60KHz...30Hz, bypass
(defined as $f_c = 300\text{KHz}/N$, where $N = 3$ to 10,000) Each channel individually programmable.
High Pass Filter: Software selectable per channel 0.1Hz or 10Hz, 1-pole Butterworth
ICP Bias Source: 2mA and 4mA, individually set on a per channel basis
Excitation Source: 0 to 5V sine, 20-100KHz range
Over-voltage protection: 10Vrms max

Triggering

Channel 1 Analog Trigger (WaveBook Module only)

Input Signal Range: -10 to +10V
Input Characteristics and Protection: Same as WaveBook channel inputs
Latency: 300ns

Multi-Channel Analog Trigger (all channels)

Range: Selectable per channel to input range
Latency: 2us/channel, plus 4us maximum

TTL Trigger

Input Signal Range: 0-5V
Input Characteristics: TTL-compatible with 10K ohm pull-up resistor
Input Protection: Zener clamped -0.7 to +5V
Latency: 300ns

Software Trigger

Latency: 100us typical

Pulse Trigger

Input Signal Range: 0-5V
Input Characteristics: 75 ohms
Input Protection: ± 10 V maximum
Minimum Pulse Width: 100ns
Latency: 300ns

External Clock

Connector: Available on DB25 input Pin 20
Input Signal Range: 5V TTL compatible
Input Characteristics: 50K ohms pull up (to +5V) in parallel with 50pF
Input Protection: Zener clamped -0.7 to +5V
Delay: 200ns
Signal Slew Rate Requirement: 20V/us minimum
Rate: Up to 1MHz
Divisor ratio: Divide by 1 through 255, selectable
Clock Counter Accuracy: <0.02% error
Clock Counter Range: 0.01Hz to 100KHz

Sequencer

Operation: Programmable for channel, gain, and for unipolar/bipolar range in random order
Depth: 128 location
Channel-to-Channel Rate: 1.0-1.1us/channel, all channels equal
Maximum Repeat Rate: 1MHz
Minimum Repeat Rate: 100 seconds per scan
Expansion Channel Sample Rate: Same as on-board channels

High-Speed Digital Inputs/General-Purpose Outputs

Connector: DB25 Female
Configuration: 16 TTL-compatible pins, selectable for input or output
Input Characteristics: TTL-compatible
Output Characteristics: ALS TTL output in series with 33 ohms
Output Updates: Outputs may be changed via program control
Input/Output Protection: Diode clamped to ground and +5V
External Clock: Pin 20

General Specifications

Warm-up: 30 minutes to rated specifications
Environment:
Operating: -10 to +55°C, 0-95% RH (non-condensing)
Storage: -40 to 70°C
Power Consumption: 100W max. plus Notebook Power utilized (50W max.)
AC Power Input Range: 100-240VAC (90-260VAC allowable), 50-400Hz
DC Power Input Range: 12-30VDC
Charging Time: 5 hours to maximum charge (operating from AC input, modules off)
Battery Backup Life: 30 minutes
Vibration: Tested to MIL Std 810E Category 1 and 10
Dimensions: 470mm wide X 369mm deep X 191 mm high (18.5" X 14.5" X 7.5")
Weight: 15kg (33 lbs)

Included Accessories and Software

Software: *WaveView*
DIAdem-View
DOS and Windows Drivers
LabView Drivers

Hardware: *CA-1, IEC Power Cable*
CA-198 5-pin DIN to vehicle cigarette lighter power cable, 10ft (3.048 m)
CA-35-2 Parallel Port Cable
HA-192 Accessory Pouch
48" (1.2m) of ST-5-6, Tape, Adhesive Foam Seal
2-10" (0.254m) of ST-27, Dual-Lock Fastener with Adhesive

Optional Accessories

Software: *DasyLab*

Hardware: *WBK30 Memory options (consult factory)*
CA-178 DB25 to external clock BNC
WBK20A PCMCIA Card/Cable
CA-150-1 Single Male BNC to Male BNC CE Compliant cable
CA-150-8 Eight Male BNC to Male BNC CE Compliant cables
Spare Filter media for fan (Qty 1)

WavePort/V Specifications

IOtech Option	Function	Internal/External
WBK11A	8-Channel Simultaneous Sample and Hold	Internal
WBK12A	8-Channel Programmable Low-pass Filter	Internal
WBK13A	8-Channel Programmable Low-pass Filter with Simultaneous Sample and Hold	Internal
WBK61, 62	High Voltage Adapters and Probes	External

This section provides Analog Specifications Applicable to:

WavePort/V8 - WaveBook (8 channels total)

WavePort/V16 - WaveBook with one expansion module (16 channels total)

WavePort/V24 - WaveBook with two expansion modules (24 channels total)

Input Voltage Ranges (DC Specifications):

Voltage Range	Standard Unit			With WBK11A (Note 3)			With WBK12A/13A (Note 3)			
	Accuracy (Note 2) One Year, 18-28°C		Input Noise LSB rms dc-500KHz (typical)	Accuracy (Note 2) One Year, 18-28°C		Input Noise LSB rms dc-500KHz (typical)	Accuracy (Note 2) One Year, 18-28°C		Input Noise LSB rms (typical)	
	± % reading	± % range		± % reading	± % range		± % reading	± % range	1KHz Filter	Filter Bypass
0 to +10V	.012%	.008%	2	.012%	.008%	2	.012%	.008%	2.2	2.2
0 to +5V (10A) 0 to +4V (516)	.012%	.009%	2	.012%	.009%	2	.012%	.009%	2.2	2.2
0 to +2V	.012%	.012%	3	.012%	.012%	3	.012%	.012%	2.2	3
0 to +1V (10A only)	.012%	.018%	3	.012%	.018%	3	.012%	.018%	2.2	3
0 to +.5V	N/A	N/A	N/A	.018%	.033%	6	.018%	.033%	2.2	6
0 to +.2V	N/A	N/A	N/A	.018%	.08%	8	.018%	.08%	2.2	12
0 to +.1V	N/A	N/A	N/A	.018%	.16%	15	.018%	.16%	2.2	20
-10 to +10V	.012%	.008%	2	.012%	.008%	2	.012%	.008%	2.2	2.2
-5 to +5V	.012%	.008%	2	.012%	.008%	2	.012%	.008%	2.2	2.2
-2 to +2V	.012%	.009%	2	.012%	.009%	2	.012%	.009%	2.2	3
-1 to +1V	.018%	.012%	3	.018%	.012%	3	.018%	.012%	2.2	3.3
-.5 to +.5V (10A only)	.018%	.018%	5	.018%	.018%	6	.018%	.018%	2.2	6
-.2 to +.2V	N/A	N/A	N/A	.018%	.033%	8	.018%	.033%	2.2	12
-.1 to +.1V	N/A	N/A	N/A	.018%	.08%	15	.018%	.08%	2.2	20
-.05 to +.05V (10A only)	N/A	N/A	N/A	.018%	.16%	26	.018%	.16%	4	40

Notes: 1. Specifications assume differential input scan, unfiltered
 2. Accuracy specification is exclusive of noise.
 3. Unipolar ranges unavailable for WaveBook with WBK11A, WBK12A, or WBK13A options installed.
 Available with Module 1 and Module 2 with any option.

System Performance: one year, 18-28°C unless otherwise noted

Differential Nonlinearity: ± 2 LSB max
Total Harmonic Distortion (10Hz-20KHz): -84dB typical
Signal to Noise and Distortion (SINAD, 10Hz-20KHz): -74dB typical
Temperature Coefficient of Accuracy (0-18 and 28-50°C):
With PGA and WBK11A: $\pm (.002\% + 0.6 \text{ LSB})/^{\circ}\text{C}$ typical, -10 to +10V range
With WBK12A/13A: $\pm (.002\% + 1 \text{ LSB})/^{\circ}\text{C}$ typical, -10 to +10V range
Input Resistance: 5M Ω (single ended); 10M Ω (differential), in parallel with 30pF
Bias Current: <400 nA (0 to 35°C)
Common Mode Rejection: >70dB minimum; >80dB typical; dc-20KHz
Input Bandwidth: dc to 500KHz
Hostile Channel-to-channel Crosstalk (5Vrms input signal, dc-100KHz): -88dB typical
Over-Voltage Protection: ± 35 V relative to analog common

PGA Filter

Filter Type: 20KHz low pass, Butterworth, 5-pole filter

WBK11A Functions

Input Voltage Ranges: Software programmable prior to a scan sequence
Aperture Uncertainty (SSH): 75ps max
Voltage Droop (SSH): 0.01mV/ms typ

WBK12A/13A Functions

Input Voltage Ranges: Software programmable prior to a scan sequence
Low Pass Filter Type: Software selectable, 8-Pole elliptic or linear phase
Anti-Aliasing Filters: Single-pole pre and post filters, automatically set depending on filter frequency selected
Low-Pass Filter Frequency Cutoff Range: 100KHz, 75KHz, 60KHz...400Hz, bypass ($f_c=300\text{KHz}/N$ where $N=3$ to 750)
Filter Grouping: 4 Channels each in two programmable banks
Aperture Uncertainty (SSH): 75ps max
Voltage Droop (SSH): 0.01mV/ms typ

Triggering**Channel 1 Analog Trigger**

Input Signal Range: -10 to +10V
Input Characteristics and Protection: Same as channel inputs
Latency: 300ns

Multi-Channel Analog Trigger (up to 72 channels):

Range: Selectable per channel to input range
Latency: 2us/channel, plus 4us maximum

TTL Trigger:

Input Signal Range: 0-5V
Input Characteristics: TTL-compatible with 10K ohm pull-up resistor
Input Protection: Zener clamped -0.7 to +5V
Latency: 300ns

Software Trigger

Latency: 100us typical

Pulse Trigger

Input Signal Range: 0-5V
Input Characteristics: 75 ohms
Input Protection: ± 10 V maximum
Minimum Pulse Width: 100ns
Latency: 300ns

External Clock

Connector: Available on DB25 digital input
Input Signal Range: 5V TTL compatible
Input Characteristics: 50K ohms pull up (to +5V) in parallel with 50pF
Input Protection: Zener clamped -0.7 to +5V
Delay: 200ns
Signal Slew Rate Requirement: 20V/us minimum
Rate: Up to 1MHz
Divisor ratio: Divide by 1 through 255, selectable
Clock Counter Accuracy: <0.02% error
Clock Counter Range: 0.01Hz to 100KHz

Sequencer

Operation: Programmable for channel, gain, and for unipolar/bipolar range in random order
Depth: 128 location
Channel-to-Channel Rate: 1.0-1.1us/channel, all channels equal
Maximum Repeat Rate: 1MHz
Minimum Repeat Rate: 100 seconds per scan
Expansion Channel Sample Rate: Same as on-board channels

High-Speed Digital Inputs/General-Purpose Outputs

Connector: DB25 Female
Configuration: 16 TTL-compatible pins, selectable for input or output
Input Characteristics: TTL-compatible
Output Characteristics: ALS TTL output in series with 33 ohms
Output Updates: Outputs may be changed via program control
Input/Output Protection: Diode clamped to ground and +5V

General Specifications

Warm-up: 30 minutes to rated specifications
Environment:
 Operating: -10 to +55°C, 0-95% RH (non-condensing)
 Storage: -40 to 70°C
Power Consumption: 100W max. plus Notebook Power utilized (50W max.)
AC Power Input Range: 100-240VAC (90-260VAC allowable), 50-400Hz
DC Power Input Range: 12-30VDC
Charging Time: 5 hours to maximum charge (operating from AC input, modules off)
Battery Backup Life: 30 minutes
Vibration: Tested to MIL Std 810E Category 1 and 10
Dimensions: 470mm wide X 369mm deep X 191 mm high (18.5" X 14.5" X 7.5")
Weight: 15kg (33 lbs)

Included Accessories and Software

Software: *WaveView*
DIAdem-View
DOS and Windows Drivers
LabView Drivers

Hardware: *CA-1, IEC Power Cable*
CA-198 5-pin DIN to vehicle cigarette lighter power cable, 10ft (3.048 m)
CA-35-2 Parallel Port Cable
HA-192 Accessory Pouch
48" (1.2m) of ST-5-6, Tape, Adhesive Foam Seal
2-10" (0.254m) of ST-27, Dual-Lock Fastener with Adhesive

Optional Accessories

Software: *DasyLab*

Hardware: *WBK30 Memory options (consult factory)*
CA-178 DB25 to external clock BNC
WBK20A PCMCIA Card/Cable
CA-150-1 Single Male BNC to Male BNC CE Compliant cable
CA-150-8 Eight Male BNC to Male BNC CE Compliant cables
Spare Filter media for fan (Qty 1)

Included Accessories and Software

Software: *WaveView*
DIAdem View
DOS and Windows Drivers
WaveCal

Hardware: *AC Adapter*
Parallel Cable
Users Manual

Overview

A low-impedance piezoelectric accelerometer consists of a piezoelectric crystal and an electronic amplifier. When stretched or compressed, the two crystal surfaces develop a charge variation that is related to the amount of stress, shock, or vibration on the crystal. The amplifier outputs a corresponding signal and transforms the sensor's high impedance to a lower output impedance of a few hundred ohms. Note that, in addition to acceleration, these sensors can also measure pressure and force.

The circuit requires only two wires (coax or twisted pair) to transmit both power and signal. At low impedance, the system is insensitive to external or "triboelectric" cable noise. Cable length does not affect sensitivity.

The figure shows a simple sensor-WBK14 connection. The voltage developed across R is applied to the gate of the MOSFET. The MOSFET is powered from a constant current source of 2 or 4 mA and 27 volts.

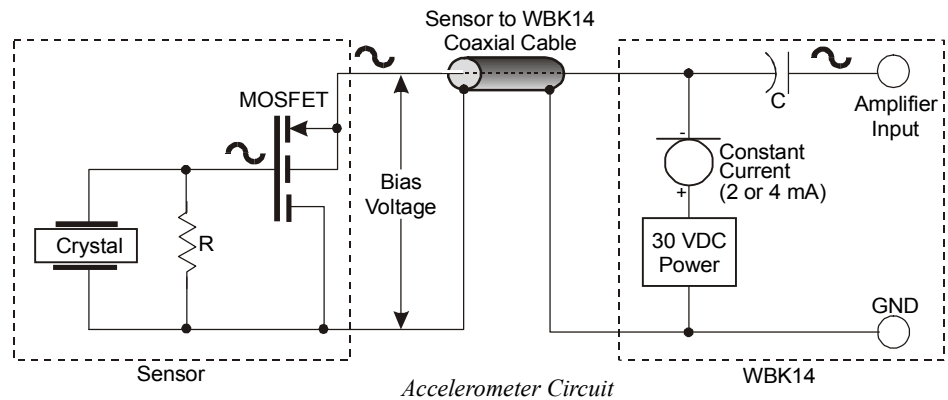

The MOSFET circuit will bias off at approximately 12 V in the quiet state. As the system is excited, voltage is developed across the crystal and applied to the gate of the MOSFET. This voltage will cause linear variation in the impedance of the MOSFET and a proportional change in bias voltage. This voltage change will be coupled to the WBK14 input amplifier through the capacitor C. The value of R and the internal capacitance of the piezoelectric crystal control the low frequency corner. Units weighing only a few grams can provide high level outputs up to 1 V/g with response to frequencies below 1 Hz.

Accelerometer Specification Parameters

Noise in Accelerometers

The noise floor or resolution specifies lowest discernible amplitude (minimum "g") that can be measured. There are two main sources of noise as follows:

- **Noise from the crystal and microcircuit inside the accelerometer.** Some types of crystals, such as quartz, are inherently more noisy than others. A good noise floor is 10 to 20 μV .
- **Noise from electrical activity on the mounting surface.** Since the signal from the accelerometer is a voltage, 60 Hz or other voltages (ground loop, etc) can interfere with the signal. The best protection is to electrically isolate the accelerometer.

Sensitivity

The sensitivity of an accelerometer is defined as its output voltage per unit input of motion. The unit of motion used is "g." One "g" is equal to the gravitational acceleration at the Earth's surface, which is 32.2 ft/(sec)(sec) or 981 cm/(sec)(sec). The output is usually specified in millivolts per "g" (mV/g).

Sensitivity is usually specified under defined conditions such as frequency, testing levels, and temperature. An example: 100 mV/g at a frequency of 100 Hz, level +1 g, at 72°F. Note that, although a sensor may have a "typical" sensitivity of 100 mV/g, its actual sensitivity could range from 95 to 105 mV/g (when checked under stated conditions). Manufacturers usually provide sensor calibration values.

Transverse Sensitivity

An accelerometer is designed to have one major axis of sensitivity, usually perpendicular to the base and co-linear with its major cylindrical axis. The output caused by the motion perpendicular to the sensing axis is called *transverse sensitivity*. This value varies with angle and frequency and typically is less than 5% of the basic sensitivity.

Base-Strain Sensitivity

An accelerometer's *base-strain sensitivity* is the output caused by a deformation of the base, due to bending in the mounting structure. In measurements on large structures with low natural frequencies, significant bending may occur. Units with low *base-strain sensitivity* should be selected. Inserting a washer (smaller in diameter than the accelerometer base) under the base reduces contact surface area; and can substantially reduce the effects of base-strain. Note that this technique lowers the usable upper frequency range.

Acoustic Sensitivity

High-level acoustic noise can induce outputs unrelated to vibration input. In general, the effect diminishes as the accelerometer mass increases. Use of a light, foam-rubber boot may reduce this effect.

Frequency Response

An accelerometer's frequency response is the ratio of the sensitivity measured at frequency (f) to the basic sensitivity measured at 100 Hz. This response is usually obtained at a constant acceleration level, typically 1 g or 10 g. Convention defines the usable range of an accelerometer as the frequency band in which the sensitivity remains within 5% of the basic sensitivity. Measurements can be made outside these limits if corrections are applied. Care should be taken at higher frequencies because mounting conditions greatly affect the frequency range (see *Mounting Effects*, in upcoming text).

Dynamic Range

The dynamic measurement range is the ratio of the maximum signal (for a given distortion level) to the minimum detectable signal (for a given signal-to-noise ratio). The dynamic range is determined by several factors such as sensitivity, bias voltage level, power supply voltage, and noise floor.

Bias Level

Under normal operation, a bias voltage appears from the output signal lead to ground. There are two basic MOSFET configurations commonly used. One exhibits a 7-8 V bias and the second a 9-12 V bias. Operation of the two circuits is identical except for the available signal swing. The low-voltage version typically exhibits 5-10 μV_{rms} versus 10-20 μV_{rms} for the high voltage.

Thermal Shock - Temperature Transients

Piezoelectric accelerometers exhibit a transient output that is a function of a temperature's "rate-of-change." This "thermal shock" is usually expressed in $g/^{\circ}\text{C}$ and is related to:

- Non-uniform mechanical stresses set up in the accelerometer structure.
- A pyroelectric effect in piezoelectric materials—an electrical charge is produced by the temperature gradient across the crystal.

This quasi-static effect produces a low-frequency voltage input to the MOSFET amplifier. This voltage is usually well below the low-frequency corner, but the effect can reduce the peak clipping level and cause loss of data. This effect does not affect the accelerometer's basic sensitivity or the data unless the thermal shift in the operation bias level results in clipping. Where drastic thermal shifts are expected, use 12 V bias models. The effect's severity is related to the mass of the accelerometer. In 100 mV/g industrial units, the effect is usually negligible. Using rubber thermal boots can reduce the effect significantly.

Overload Recovery

Recovery time from clipping due to over-ranging is typically less than 1 ms. Recoveries from quasi-static overloads that generate high DC bias shifts are controlled by the accelerometer input RC time constant that is fixed during manufacture.

Power Supply Effects

The nominal power supply voltage recommended by most manufacturers is 15 to 24 V. Units may be used with voltages up to 28 volts. Sensitivity variations caused by voltage change is typically 0.05%/volt. Power supply ripple should be less than 1 mVrms.

Connector

This parameter specifies the connector type and size (4-48, 6-40, 10-32 coaxial etc) and the location on the sensor, that is, top or side (usually on the hex base). Where there is no connector on the sensor, an integral cable is specified with the length and the connector, that is, integral 6-ft to 10-32.

Electrical Grounding

Case-Grounded Design

In case-grounded designs, the common lead on the internal impedance matching electronics is tied to the accelerometer case. The accelerometer base/stud assembly forms the signal common and electrically connects to the shell of the output connector. Case-grounded accelerometers are connected electrically to any conductive surface on which they are mounted. When these units are used, take care to avoid errors due to ground noise.

Isolated-Base Design

To prevent ground noise error many accelerometers have base-isolated design. The outer case/base of the accelerometer is isolated electrically off ground by means of an isolation stud insert. The proprietary material used to form the isolation provides strength and stiffness to preserve high-frequency performance.

Cable Driving

Operation over long cables is a concern with all types of sensors. Concerns involve cost, frequency response, noise, ground loops, and distortion caused by insufficient current available to drive the cable capacitance.

The cost of long cables can be reduced by coupling a short (1 m) adapter cable from the accelerometer to a long low-cost cable like RG-58U or RG-62U with BNC connectors. Since cable failure tends to occur at the accelerometer connection where the vibration is the greatest, only the short adapter cable would need replacement.

Capacitive loading in long cables acts like a low-pass, second-order filter and can attenuate or amplify high-frequency signals depending on the output impedance of the accelerometer electronics. Generally this is not a problem with low-frequency vibration (10 Hz to 2000 Hz). For measurements above 2000 Hz and cables longer than 100 ft, the possibility of high-frequency amplification or attenuation should be considered.

The WBK14 constant-current source provides 2 or 4 mA to integral electronics. Use the higher current setting for long cables, high peak voltages, and high signal frequencies.

The maximum frequency that can be transmitted over a given length of cable is a function of both the cable capacitance and the ratio of the maximum peak signal voltage to the current available from the constant current source:

Drive Current (mA)	Cable Length @30 pF/ft (Ft)	Frequency Response to 5% of Maximum Output Signal Amplitude	
		± 1 V	± 5 V
2	10	185 kHz	37 kHz
2	100	18.5 kHz	3.7 kHz
2	1000	1.85 kHz	370 Hz
4	10	550 kHz	110 kHz
4	100	55 kHz	11 kHz
4	1000	5.5 kHz	1.1 kHz

Where:

f = Maximum frequency in Hz

$K = 3.45 \times 10^9$. K is the scale factor to convert Farads to picoFarads and Amperes to milliAmperes and a factor to allow cable capacitance to charge to 95% of the final charge.

C = Cable capacitance in picoFarads

V = Maximum peak measured voltage from sensor in volts

I_{cc} = Constant current from current source in mA

I_b = Current required to bias the internal electronics, typically 1 mA

$$f = \frac{K}{2\pi C \left(\frac{V}{I_{cc} - I_b} \right)}$$

WBK14 - Specifications

Specifications are provided in Chapter 11.

Instead of using the supplied CA-35-2 enhanced parallel port (EPP) cable to connect WavePort to the Notebook PC, you can connect your WavePort to the Notebook with a WBK20A, PCMCIA Interface Card.



Reference Note:

WBK20A is shipped with a *PC-Card-to-Parallel-Port Adapters User's Manual*. Refer to that document for installation details.

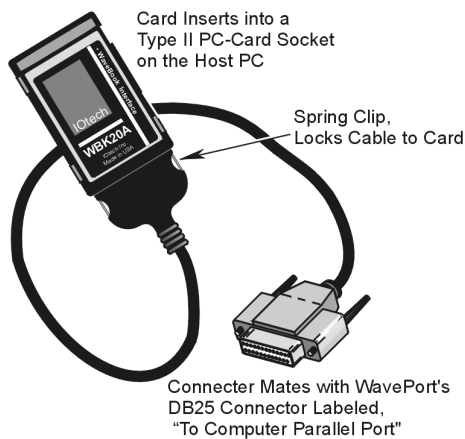

To link a WavePort to a Notebook using a WBK20A:

1. Insert the WBK20A card into a Type II PCMCIA socket on the Notebook.
2. Connect cable (CA-191-1) to the PCMCIA card.
3. Connect the cable's DB-25 socket-connector to WavePort's DB25 plug connector labeled "TO COMPUTER PARALLEL PORT."
4. Load the required software drivers by following the instructions provided with the WBK20A.

Note that no hardware configuration is required. Software configuration is performed from within the provided software.



Record the WBK20A IRQ interrupt setting for future reference.



To ensure proper operation of WBK20A card, you will need to boot up the notebook computer with the WBK20A inserted in the PC's card slot. Failure to do so may prevent the application software from recognizing the card as a parallel port device.



You can use the earlier version WBK20 card/cable to connect your WavePort to a Notebook PC. WBK20 is identical to WBK20A in performance, but requires a different cable (CA-157-1). WBK20A uses cable CA-191-1, which locks to the card.

It is important to note that these two cables are not interchangeable.

Glossary

Acquisition

A collection of scans acquired at a specified rate as controlled by the sequencer.

Analog signal

A signal of varying voltage or current, resistance, temperature such as the output of a sensor.

Analog-to-Digital Converter (ADC)

A circuit or device that converts analog signals into digital values, such as binary bits, for use in digital computer processing.

API

Application Program Interface. The interface program within the WaveView system's driver that includes function calls specific to WavePort hardware and can be used with user-written programs (several languages supported).

Bipolar

A range of analog signals with positive and negative values (e.g., -5 to +5 V); see *unipolar*.

Buffer

Buffer refers to a circuit or device that allows a signal to pass through it, while providing isolation, or another function, without materially altering the signal. *Buffer* usually refers to:

- (a) A device or circuit that allows for the temporary storage of data during data transfers. Such storage can compensate for differences in data flow rates. In a FIFO (First In - First Out) buffer, the data that is stored first is also the first data to leave the buffer.
- (b) A follower stage used to drive a number of gates without overloading the preceding stage.
- (c) An amplifier which accepts high source impedance input and results in low source impedance output (effectively, an impedance buffer).
- (d) Buffer Amplifier (see *Buffer Amplifier*).

Buffer Amplifier

An amplifier used primarily to match two different impedance points, and isolate one stage from a succeeding stage in order to prevent an undesirable interaction between the two stages. (Also see, *Buffer*).

Channel

In reference to WavePort, *channel* simply refers to a single *input*, or *output* entity.

In a broader sense, an *input channel* is a signal path between the transducer at the point of measurement and the data acquisition system. A channel can go through various stages (buffers, multiplexers, or signal conditioning amplifiers and filters). Input channels are periodically sampled for readings.

An *output channel* from a device can be digital or analog. Outputs can vary in a programmed way in response to an input channel signal.

Common mode

Common mode pertains to signals that are identical in amplitude and duration; also can be used in reference to signal components.

Common mode voltage

Common mode voltage refers to a voltage magnitude (referenced to a common point) that is shared by 2 or more signals. Example: referenced to common, Signal 1 is +5 VDC and Signal 2 is +6 VDC. The common mode voltage for the two signals is +5.5 VDC $[(5 + 6)/2]$.

Crosstalk

An undesired transfer of signals between system components or channels. Crosstalk often causes signal interference, more commonly referred to as *noise*.

Digital-to-Analog Converter (DAC)

A circuit or device that converts digital values (binary bits), into analog signals.

Differential mode

The differential mode measures a voltage between 2 signal lines for a single channel. (Also see *single-ended mode*).

Differential mode voltage

Differential mode voltage refers to a voltage difference between two signals that are referenced to a common point.

Example: Signal 1 is +5 VDC referenced to common. Signal 2 is: +6 VDC referenced to common.

If the +5 VDC signal is used as the reference, the differential mode voltage is:

$$+1 \text{ VDC } (+6 \text{ VDC} - +5 \text{ VDC} = +1 \text{ VDC}).$$

If the +6 VDC signal is used as the reference, the differential mode voltage is:

$$-1 \text{ VDC } (+5 \text{ VDC} - +6 \text{ VDC} = -1 \text{ VDC}).$$

ESD

Electrostatic discharge (ESD) is the transfer of an electrostatic charge between bodies having different electrostatic potentials. This transfer occurs during direct contact of the bodies, or when induced by an electrostatic field. ESD energy can damage an integrated circuit (IC).

Excitation

Some transducers [e.g. strain gages, thermistors, and resistance temperature detectors (RTDs)] require a known voltage or current input in order for the sensor to operate. This known input is called the Excitation.

Gain

The degree to which a signal is amplified (or attenuated) to allow greater accuracy and resolution; can be expressed as $\times n$ or $\pm \text{dB}$.

Isolation

The arrangement or operation of a circuit so that signals from another circuit or device do not affect the *isolated* circuit. In reference to WavePort, *isolation* usually refers to a separation of the direct link between the signal source and the analog-to-digital converter (ADC). Isolation is necessary when measuring high common-mode voltage.

Linearization

Some transducers produce a voltage in linear proportion to the condition measured. Other transducers (e.g., thermocouples) have a nonlinear response. To convert nonlinear signals into accurate readings requires software to calibrate several points in the range used and then interpolate values between these points.

Multiplexer (MUX)

A device that selects a signal from among several signals and outputs it on a single channel.

Sample (reading)

The value of a signal observed on a channel at an instant in time. When triggered, the ADC reads the channel and converts the sampled value into a digital representation.

Scan

A series of measurements across a pre-selected sequence of channels.

Sequencer

Defines and controls the state of the measurement system for each step of a scan.

Simultaneous Sample-and-Hold

An operation that captures samples from multiple channels at the same instant in time. The result is elimination of time skew between measurement of individual channels.

Single-ended mode

Measurement of a voltage between a signal line and some reference that may be shared with other channels. (Also see *differential mode*).

Trigger

An event to start a scan or mark an instant during an acquisition. A trigger can be a TTL signal, a specified signal level, a button manually or mechanically engaged, or a software command.

TTL

Transistor-Transistor Logic (TTL) typically used to communicate logic signals where a logical 0 is defined by a voltage level of <0.8V and logical 1 is defined as 2.4-5V.

Unipolar

A range of analog signals between zero and some positive value (e.g., 0 to 10 V).

